



OPTISONIC 8300 Technical Datasheet

Ultrasonic flowmeter
for high-temperature gas and superheated steam

- Excellent long term stability, no pressure drop
- Wide measurement range of 60:1
- High accuracy of 1% of MV, suitable for custody transfer measurement



1	Product features	3
<hr/>		
1.1	Ultrasonic gas flowmeter for high-temperature gas and superheated steam	3
1.2	Options and variants	5
1.3	Features.....	6
1.4	Measuring principle.....	8
2	Technical data	9
<hr/>		
2.1	Technical data.....	9
2.2	Dimensions and weight	21
2.2.1	Converter housing.....	22
2.2.2	Mounting plate of field housing	22
3	Installation	23
<hr/>		
3.1	General notes on installation	23
3.2	Intended use	23
3.3	General requirements	24
3.3.1	Vibration	24
3.4	General requirements sensor	25
3.4.1	Inlet and outlet	25
3.4.2	Bends in 2 or 3 dimensions.....	26
3.4.3	T-section	26
3.4.4	Mounting position.....	27
3.4.5	Flange deviation	28
3.4.6	Control valve	28
3.4.7	Thermal insulation.....	29
4	Electrical connections	30
<hr/>		
4.1	Safety instructions.....	30
4.2	Connection of signal cable to signal converter.....	30
4.3	Power supply connection	32
4.4	Input and outputs, overview	34
4.4.1	Combinations of the inputs/outputs (I/Os)	34
4.4.2	Description of the CG number	35
4.4.3	Fixed, non-alterable input/output versions.....	36
4.4.4	Alterable input/output versions.....	37
5	Application form	38
<hr/>		

1.1 Ultrasonic gas flowmeter for high-temperature gas and superheated steam

The **OPTISONIC 8300** offers a robust and accurate gas flow measurement based on ultrasonic transit time technology specially designed for high-temperature gas or superheated steam applications.

The flowmeter is in particular a great solution for superheated steam measurement either whether for accurate process flow control or fiscal custody transfer. In a world with rising energy costs and concerns for the environment, accurate steam measurement is getting more and more important. Steam measurement with an ultrasonic flowmeter represents nowadays the best available technology and a state of the art engineered solution. Cost-saving on energy, installation and maintenance together with highly precise and long-term stable measurement over a wide dynamic flow range, makes the OPTISONIC 8300 simply the best choice. There is no need for recalibration and the onboard self-diagnostic monitors continuously the correct performance during operation. In an easy way, periodically on-site and in-line verifications without interrupting the process can be performed.

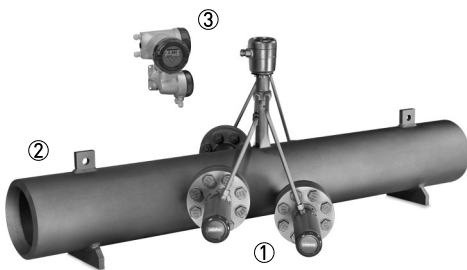

- ① Flow sensor with two parallel paths for optimal accuracy
- ② Flanged or weld-in design
- ③ Remote converter

The measuring system consist of an OPTISONIC 8000 flow sensor and a smart GFC 300 remote mounted signal converter with integrated flow computer functionalities and extensive self-diagnostics. With the available temperature and pressure inputs, the GFC 300 converter has the possibility to calculate mass flow and enthalpy in addition to the volumetric flow. This provides additional costs savings because there is no need for the added cost of a flow computer or external calculations.

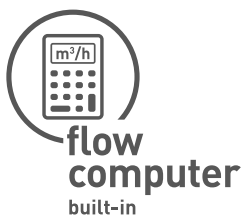

Flow computer built-in

Many KROHNE flowmeters have a built-in flow computer that compensates for the effects of pressure and temperature on the flow measurement or to convert to standard volume. The OPTISONIC 7300/8300 have analogue input for P & T sensors, the OPTISWIRL 4200 has both integrated. This saves both cost and installation efforts for an external flow computer.

Highlights

- Full bore unobstructed and maintenance-free sensor tube
- Excellent long- term measurement stability, no drift over time
- Accurate bi-directional flow measurement with a wide dynamic flow range (60:1)
- Self-Diagnostics to monitor for correct operation and to support periodical verifications
- Integrated mass flow and enthalpy calculation according to IAPWS-IF97, using pressure and temperature input

Industries

- Chemical and Petrochemical
- Power plants
- Refineries
- Tank terminals

Applications

- High-temperature gas applications
- Allocation of steam production
- Custody transfer of steam
- Steam turbine performance management
- Custody transfer of steam
- Vent lines with hazardous area (zone 0) classification

1.2 Options and variants

The **OPTISONIC 8300** is a single (4" / DN100) or dual path (≥ 6" / DN150) ultrasonic gas flowmeter designed for the measurement of superheated steam and high-temperature gases. The usage of patented transducer technology ensures durable and reliable measurement.



Application range

- Diameter range DN100...600 / 4...24", extended range up to DN1000 / 40"
- Temperature up to 540°C / 1004 °F, extended temperature up to 620°C / 1148 °F
- Pressure standard up to 100 bar / 1450 psi, extended pressure up to 200 bar / 2901 psi

Connection options

- Flangeless (weld-in) process connection
- Standard flange ratings available up to ASME 600 lbs / PN100
- Extended pressure versions up to 2500 lbs / PN250

Output options

- Flow speed and Actual Volume
- Velocity of sound of medium
- Mass flow and enthalpy by using the integrated flow computer option

Calibration

- Standard: air calibration
- Optional: Reynolds calibration on pressurized natural gas



Remote GFC 300 signal converter

- Display with 4 optical buttons
- I/O configurations available
- One universal software for all applications
- Monitoring Tool connection

1.3 Features



Highly accurate flow measurement

Accuracy better than 1% thanks to two parallel path design.

Velocity of Sound (VOS) monitoring

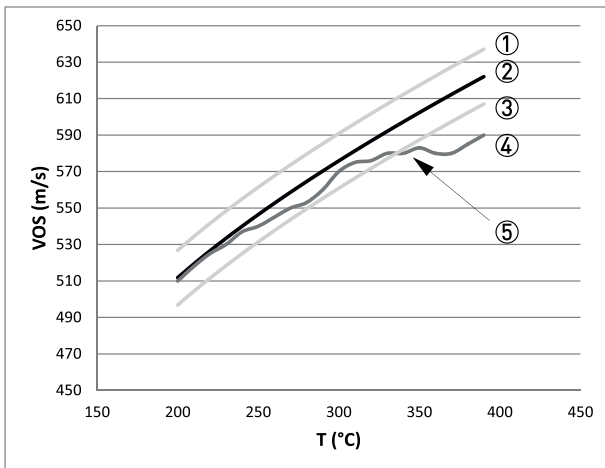

- ① VOS upper limit
- ② VOS calculated
- ③ VOS lower limit
- ④ VOS measured
- ⑤ VOS alarm trip

Diagnostics for verification

The OPTISONIC 8300 provides a number of online diagnostic parameters and functions. For example since the process medium is known, the velocity of sound can be calculated with the input of temperature and pressure. The calculated velocity of sound can be monitored against the measured value. In this way not only the flow sensor is continuously diagnosed but also the temperature and the pressure sensor.

In addition, the diagnostics parameters can be used for in-situ verification of the steam flowmeter by comparing diagnostics values recorded at initial calibration or at commissioning, with actual values. In this way, an accurate and reliable measurement can be guaranteed continuously.

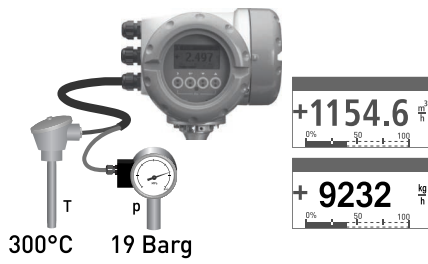

ATEX / IECEx

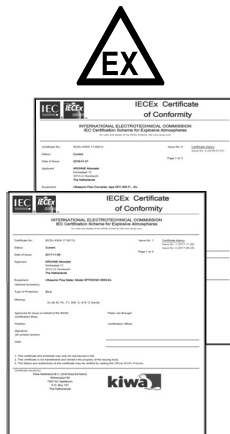

Mass flow and energy flow calculation

The OPTISONIC 8300 integrates the functionality of a flow computer in a flowmeter. Two optional current inputs for pressure and temperature allow the OPTISONIC 8300 to provide output like corrected volume flow, mass flow and energy flow. In case more flexibility or I/O options are required, the flowmeter can also be combined with the Summit flow computer.

ATEX / IEC-Ex certification incl. zone 0. In the case, gas flow must be measured in vent lines where a combination of flammable gases and oxygen may occur, the OPTISONIC 8300 can be used since it is Ex certified for zone 0 inside the tube.

1.4 Measuring principle

- Like canoes crossing a river, acoustic signals are transmitted and received along a diagonal measuring path.
- A sound wave going downstream with the flow travels faster than a sound wave going upstream against the flow.
- The difference in-transit time is directly proportional to the mean flow velocity of the medium.

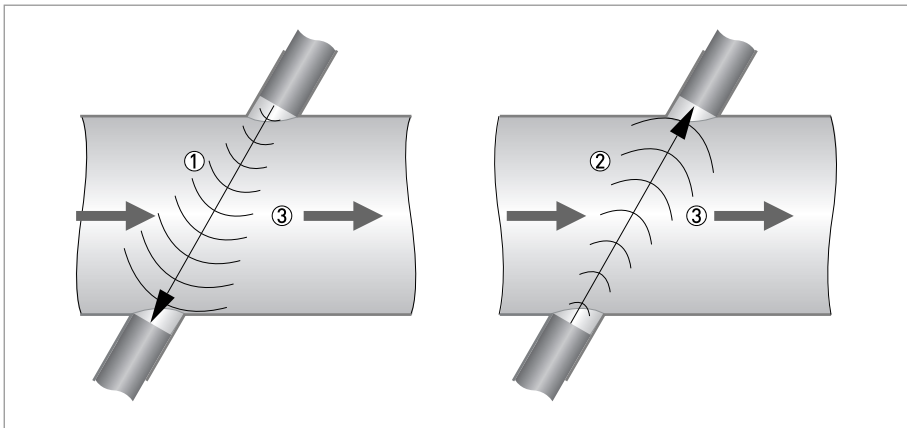

Figure 1-1: Measuring principle

- ① Sound wave against the flow direction
- ② Sound wave with the flow direction
- ③ Flow direction

2.1 Technical data

- *The following data is provided for general applications. If you require data that is more relevant to your specific application, please contact us or your local sales office.*
- *Additional information (certificates, special tools, software,...) and complete product documentation can be downloaded free of charge from the website (Downloadcenter).*

Measuring system

Measuring principle	Ultrasonic transit time
Application range	Flow measurement of superheated steam and other high-temperature gases
Measured value	
Primary measured values	Transit time
Secondary measured values	Volume flow, corrected volume flow, mass flow, molar mass, flow speed, flow direction, velocity of sound, gain, signal to noise ratio, reliability of flow measurement, totalised volume or mass

Design

Features	1 or 2 parallel acoustic path(s), fully welded flow sensor with flanged mounted High Temperature transducers.
Modular construction	The measurement system consists of a flow sensor and a signal converter.
Remote version	In field (F) mount version: OPTISONIC 8000 F flow sensor with remote installed GFC 300 F signal converter.
Nominal diameter	1 path: DN100 / 4"
	2 paths: DN150...600 / 6...24"
	On request: DN700...1000 / 28...40"
Measurement range	1...60 m/s / 3...197 ft/s, bi-directional
Input / output options	
Inputs/outputs	Current output (including HART®), pulse output, frequency output and/or status output, limit switch and/or control input, current inputs (depending on the I/O version)
Counters	2 internal counters with a max. of 8 counter places (e.g. for counting volume and/or mass units).
Self-diagnostics	Integrated verification, diagnosis functions, flowmeter, process, measured value, bar graph
Communication interfaces	Hart 5®, Foundation Fieldbus, Modbus RS485

Display and user interface	
Graphic display	LC display, backlit white
	Size: 128 x 64 pixels, corresponds to 59 x 31 mm = 2.32" x 1.22"
	Display turnable in 90° steps.
	Ambient temperatures below -25°C / -13°F, may affect the readability of the display.
Operator elements	4 optical buttons for operator control of the signal converter without opening the housing.
	Option: Infrared interface for reading and writing all parameters with IR interface without opening the housing.
Remote control	PACTware™ including Device Type Manager (DTM)
	HART® Hand Held Communicator from Emerson Process
	AMS® from Emerson Process
	PDM® from Siemens
	All DTM's and drivers are available free of charge from the manufacturer's website.
Display functions	
Operating menu	Setting the parameters using 2 measured value pages, 1 status page, 1 graphics page (measured values and graphics are freely adjustable).
Language of display texts	Available languages: English, French, German, Russian
Measurement functions	Units: Metric, British and US units selectable from list / free unit.
	Measured values: volume flow, corrected volume flow, mass flow, flow speed, velocity of sound, gain, signal to noise ratio, flow direction, diagnostics.

Measuring accuracy

Volume flow	
Reference conditions for calibration	Medium: air
	Temperature: 20°C / 68°F
	Pressure: 1 bar / 14.5 psi
	Reynold > 10000
Air calibration (standard)	DN100 / 4": < ± 1.5% of actual measured flow rate
	DN150...600 / 6...24": < ± 1% of actual measured flow rate
Repeatability	< ± 0.2%
Mass flow	
Reference conditions for calibration	Medium: Pressurised Natural Gas
	Temperature: depending on calibration
	Pressure: depending on calibration
Pressurised natural gas calibration (optional)	Calculations and correction in GFC 300 signal converter or Summit flow computer
	DN100 / 4": ≤ ± 1.5% of actual measured mass flow
	DN150...600 / 6...24": ≤ ± 1% of actual measured mass flow
Repeatability	< ± 0.2%

Operating conditions

Temperature	
Process temperature	Standard version: -25...+540°C / -13...+1004°F
	Extended option: -25...+620°C / -13...+1148°F
	Higher temperatures on request
Ambient temperature	Flow sensor: -40...+70°C / -40...+158°F
	Converter with aluminum housing: -40...+65°C / -40...+149°F
	Converter with a stainless steel housing: -40...+60°C / -40...+131°F
	Ambient temperatures below -25°C / -13°F may affect the readability of the display.
Protect the signal converter from external heat sources such as direct sunlight, as higher temperatures reduce the life cycle of all electronic components.	
Storage temperature	-50...+70°C / -58...+158°F
Pressure	
Flanged	According to flange type and rating, maximum pressure limited
Flangeless (weld in) connection	According to design pressure
Transducer design	SS347: 100 barg +540°C / 1465 psia at +1004°F
	INCONEL [®] Alloy 625: 200 barg at 620°C / 2930 psia +1148°F
Properties of medium	
Physical condition	Superheated steam (>15°C overheated), high-temperature gas
Density	Standard: 0.6...150 kg/m ³ / 0.037...9.36 lb/ft ³

Installation conditions

Installation	For detailed information see chapter "Installation".
Inlet run	≥ 20 DN
Outlet run	≥ 3 DN
Dimensions and weights	For detailed information see chapter "Dimensions and weights".

Materials

Sensor	
Flanges	Standard: carbon steel ASTM A105 N
	Optional: high-temperature steel like for example F-11, F-22.
Tube and transducer nozzles	Standard: carbon steel ASTM A106 Gr. B or equivalent (For flangeless design: according to pipe specification)
	Optional: high-temperature steel like for example P-11, P-22.
Transducers	Standard: stainless steel 347 (UNS S34700, W. nr.:1.4550)
	High pressure: INCONEL [®] Alloy 625 (UNS N06625, W. nr.:2.4856).
Tube transducer cabling	Stainless steel 316 L (1.4401)
Connection box	Stainless steel 316 L (1.4408)
Coating (flow sensor)	Standard: blasted, corrosion preservative.
	Optional: high temperature coating
NACE conformity	Optional wetted materials are conform NACE MR0175/0103
Signal converter housing	
Field version (only)	Standard: die-cast aluminium
	Ex or optional: stainless steel 316 L (1.4408)
Coating (converter housing)	Standard

Electrical connections

Power supply	Standard
	100...230 VAC (-15% / +10%), 50/60 Hz
	Option
	24 VDC (-55% / +30%) 24 VAC/DC (AC: -15% / +10%; DC: -25% / +30%)
Power consumption	AC: 22 VA
	DC: 12 W
Signal cable	Shielded cable with 2 triax cores, 1 cable per path: Ø 10.6 mm / 0.4".
	Class 1 Div 1/2: single coax cables for fitting in conduit (2 per acoustic path).
	5 m / 16 ft
	Option: max. 30 m / 90 ft
Cable entries	Standard: M20 x 1.5 (8...12 mm)
	Option: ½" NPT, PF ½ adapter

Inputs and outputs

General	All inputs and outputs are galvanically isolated from each other and from all other circuits		
	All operating data and output values can be adjusted.		
Description of used abbreviations	V_{int} = internal voltage; V_{ext} = external voltage; R_L = resistance of load; V_{nom} = nominal voltage V_0 = terminal voltage; I_{nom} = nominal current Safety limit values (Ex i): V_i = max. input voltage; I_i = max. input current; P_i = max. input power rating; C_i = max. input capacity; L_i = max. input inductivity		
Current output			
Output data	Measurement of volume flow, corr. volume flow, mass flow, molar mass, flow speed, velocity of sound, gain, diagnostics 1, 2, 3, HART® communication.		
Temperature coefficient	Typically ± 30 ppm/K		
Settings	Without HART®		
	Q = 0%: 0...15 mA		
	Q = 100%: 10...20 mA		
	Error identification: 3...22 mA		
	With HART®		
	Q = 0%: 4...15 mA		
	Q = 100%: 10...20 mA		
	Error identification: 3.5...22 mA		
Operating data	Basic I/Os	Modular I/Os	Ex i
Active	$V_{int} = 24$ VDC		$V_{int} = 20$ VDC
	$I \leq 22$ mA		$I \leq 22$ mA
Passive	$R_L \leq 1$ k Ω		$R_L \leq 450$ Ω
			$V_0 = 21$ V $I_0 = 90$ mA $P_0 = 0.5$ W $C_0 = 90$ nF / $L_0 = 2$ mH $C_0 = 110$ nF / $L_0 = 0.5$ mH
Passive	$V_{ext} \leq 32$ VDC		$V_{ext} \leq 32$ VDC
	$I \leq 22$ mA		$I \leq 22$ mA
Passive	$V_0 \geq 1.8$ V		$V_0 \geq 4$ V
	$R_L \leq (V_{ext} - V_0) / I_{max}$		$R_L \leq (V_{ext} - V_0) / I_{max}$
Passive			$V_I = 30$ V $I_I = 100$ mA $P_I = 1$ W $C_I = 10$ nF $L_I = 0$ mH

HART®			
Description	HART® protocol via active and passive current output		
	HART® version: V5		
	Universal HART® parameter: completely integrated		
Load	≥ 250 Ω at HART® test point Note maximum load for current output!		
Multidrop	Yes, current output = 4 mA		
	Multidrop addresses adjustable in operation menu 1...15		
Device drivers	HART®, AMS DD / FDT / DTM		
Pulse or frequency output			
Output data	Pulse output: volume, enthalpy or mass flow		
	Frequency output: volume flow, enthalpy flow, mass flow, specific enthalpy, density, flow speed, velocity of sound, gain		
Function	Adjustable as pulse or frequency output		
Settings	For Q = 100%: 0.01... 10000 pulses per second or pulses per unit volume.		
	Pulse width: adjustable as automatic, symmetric or fixed (0.05...2000 ms)		
Operating data	Basic I/Os	Modular I/Os	Ex i
Active	-	$V_{int} = 24 \text{ VDC}$ f_{max} in operating menu set to: $f_{max} \leq 100 \text{ Hz}$ $I \leq 20 \text{ mA}$ $R_{L, max} = 47 \text{ k}\Omega$ open: $I \leq 0.05 \text{ mA}$ closed: $V_{0, nom} = 24 \text{ V}$ at $I = 20 \text{ mA}$	-
		f_{max} in operating menu set to: $100 \text{ Hz} < f_{max} \leq 10 \text{ kHz}$ $I \leq 20 \text{ mA}$ $R_L \leq 10 \text{ k}\Omega$ for $f \leq 1 \text{ kHz}$ $R_L \leq 1 \text{ k}\Omega$ for $f \leq 10 \text{ kHz}$ open: $I \leq 0.05 \text{ mA}$ closed: $V_{0, nom} = 22.5 \text{ V}$ at $I = 1 \text{ mA}$ $V_{0, nom} = 21.5 \text{ V}$ at $I = 10 \text{ mA}$ $V_{0, nom} = 19 \text{ V}$ at $I = 20 \text{ mA}$	

Passive	$V_{\text{ext}} \leq 32 \text{ VDC}$		-
	f_{max} in operating menu set to: $f_{\text{max}} \leq 100 \text{ Hz}$ $I \leq 100 \text{ mA}$ $R_{L, \text{max}} = 47 \text{ k}\Omega$ $R_{L, \text{max}} = (V_{\text{ext}} - V_0) / I_{\text{max}}$ open: $I \leq 0.05 \text{ mA}$ at $V_{\text{ext}} = 32 \text{ VDC}$ closed: $V_{0, \text{max}} = 0.2 \text{ V}$ at $I \leq 10 \text{ mA}$ $V_{0, \text{max}} = 2 \text{ V}$ at $I \leq 100 \text{ mA}$		
	f_{max} in operating menu set to: $100 \text{ Hz} < f_{\text{max}} \leq 10 \text{ kHz}$ $I \leq 20 \text{ mA}$ $R_L \leq 10 \text{ k}\Omega$ for $f \leq 1 \text{ kHz}$ $R_L \leq 1 \text{ k}\Omega$ for $f \leq 10 \text{ kHz}$ $R_{L, \text{max}} = (V_{\text{ext}} - V_0) / I_{\text{max}}$ open: $I \leq 0.05 \text{ mA}$ at $V_{\text{ext}} = 32 \text{ VDC}$ closed: $V_{0, \text{max}} = 1.5 \text{ V}$ at $I \leq 1 \text{ mA}$ $V_{0, \text{max}} = 2.5 \text{ V}$ at $I \leq 10 \text{ mA}$ $V_{0, \text{max}} = 5.0 \text{ V}$ at $I \leq 20 \text{ mA}$		
NAMUR	-	Passive to EN 60947-5-6 open: $I_{\text{nom}} = 0.6 \text{ mA}$ closed: $I_{\text{nom}} = 3.8 \text{ mA}$	Passive to EN 60947-5-6 open: $I_{\text{nom}} = 0.43 \text{ mA}$ closed: $I_{\text{nom}} = 4.5 \text{ mA}$
			$V_I = 30 \text{ V}$ $I_I = 100 \text{ mA}$ $P_I = 1 \text{ W}$ $C_I = 10 \text{ nF}$ $L_I = 0 \text{ mH}$

Status output / limit switch			
Function and settings	Settable as indicator for direction of flow, overflow, error, operating point.		
	Status and/or control: ON or OFF		
Operating data	Basic I/Os	Modular I/Os	Ex i
Active	-	$V_{int} = 24 \text{ VDC}$ $I \leq 20 \text{ mA}$ $R_{L, max} = 47 \text{ k}\Omega$ open: $I \leq 0.05 \text{ mA}$ closed: $V_{0, nom} = 24 \text{ V}$ at $I = 20 \text{ mA}$	-
Passive	$V_{ext} \leq 32 \text{ VDC}$ $I \leq 100 \text{ mA}$ $R_{L, max} = 47 \text{ k}\Omega$ $R_{L, max} = (V_{ext} - V_0) / I_{max}$ open: $I \leq 0.05 \text{ mA}$ at $V_{ext} = 32 \text{ VDC}$ closed: $V_{0, max} = 0.2 \text{ V}$ at $I \leq 10 \text{ mA}$ $V_{0, max} = 2 \text{ V}$ at $I \leq 100 \text{ mA}$	$V_{ext} \leq 32 \text{ VDC}$ $I \leq 100 \text{ mA}$ $R_{L, max} = 47 \text{ k}\Omega$ $R_{L, max} = (V_{ext} - V_0) / I_{max}$ open: $I \leq 0.05 \text{ mA}$ at $V_{ext} = 32 \text{ VDC}$ closed: $V_{0, max} = 0.2 \text{ V}$ at $I \leq 10 \text{ mA}$ $V_{0, max} = 2 \text{ V}$ at $I \leq 100 \text{ mA}$	-
NAMUR	-	Passive to EN 60947-5-6 open: $I_{nom} = 0.6 \text{ mA}$ closed: $I_{nom} = 3.8 \text{ mA}$	Passive to EN 60947-5-6 open: $I_{nom} = 0.43 \text{ mA}$ closed: $I_{nom} = 4.5 \text{ mA}$ <hr/> $V_I = 30 \text{ V}$ $I_I = 100 \text{ mA}$ $P_I = 1 \text{ W}$ $C_I = 10 \text{ nF}$ $L_I = 0 \text{ mH}$

Control input			
Function	Set value of the outputs to "zero", counter and error reset, range change.		
Operating data	Basic I/Os	Modular I/Os	Ex i
Active	-	$V_{int} = 24 \text{ VDC}$ Terminals open: $V_{0, nom} = 22 \text{ V}$ Terminals bridged: $I_{nom} = 4 \text{ mA}$ On: $V_0 \leq 10 \text{ V}$ with $I_{nom} = 1.9 \text{ mA}$ Off: $V_0 \geq 12 \text{ V}$ with $I_{nom} = 1.9 \text{ mA}$	-
Passive	$V_{ext} \leq 32 \text{ VDC}$ $I_{max} = 6.5 \text{ mA}$ at $V_{ext} \leq 24 \text{ VDC}$ $I_{max} = 8.2 \text{ mA}$ at $V_{ext} \leq 32 \text{ VDC}$ Contact closed (On): $V_0 \geq 8 \text{ V}$ with $I_{nom} = 2.8 \text{ mA}$ Contact open (Off): $V_0 \leq 2.5 \text{ V}$ with $I_{nom} = 0.4 \text{ mA}$	$V_{ext} \leq 32 \text{ VDC}$ $I_{max} = 9.5 \text{ mA}$ at $V_{ext} \leq 24 \text{ V}$ $I_{max} = 9.5 \text{ mA}$ at $V_{ext} \leq 32 \text{ V}$ Contact closed (On): $V_0 \geq 3 \text{ V}$ with $I_{nom} = 1.9 \text{ mA}$ Contact open (Off): $V_0 \leq 2.5 \text{ V}$ with $I_{nom} = 1.9 \text{ mA}$	$V_{ext} \leq 32 \text{ VDC}$ $I \leq 6 \text{ mA}$ at $V_{ext} = 24 \text{ V}$ $I \leq 6.6 \text{ mA}$ at $V_{ext} = 32 \text{ V}$ On: $V_0 \geq 5.5 \text{ V}$ or $I \geq 4 \text{ mA}$ Off: $V_0 \leq 3.5 \text{ V}$ or $I \leq 0.5 \text{ mA}$
			$V_I = 30 \text{ V}$ $I_I = 100 \text{ mA}$ $P_I = 1 \text{ W}$ $C_I = 10 \text{ nF}$ $L_I = 0 \text{ mH}$
NAMUR	-	Active to EN 60947-5-6 Contact open: $V_{0, nom} = 8.7 \text{ V}$ Contact closed (On): $I_{nom} = 7.8 \text{ mA}$ Contact open (off): $V_{0, nom} = 6.3 \text{ V}$ with $I_{nom} = 1.9 \text{ mA}$ Identification for open terminals: $V_0 \geq 8.1 \text{ V}$ with $I \leq 0.1 \text{ mA}$ Identification for short circuited terminals: $V_0 \leq 1.2 \text{ V}$ with $I \geq 6.7 \text{ mA}$	-

Low-flow cutoff			
On	0...±9.999 m/s; 0...20.0%, settable in 0.1% steps, separately for each current and pulse output.		
Off	0...±9.999 m/s; 0...19.0%, settable in 0.1% steps, separately for each current and pulse output.		
Time constant			
Function	Can be set together for all flow indicators and outputs, or separately for: current, pulse and frequency output, and for limit switches and the 3 internal counters.		
Time setting	0...100 seconds, settable in 0.1-second steps.		
Current input			
Function	For conversion to standard conditions, input from external temperature and pressure transmitters is required.		
Operating data	Basic I/Os	Modular I/Os	Ex i
Active	-	$V_{\text{int}} = 24 \text{ VDC}$	$V_{\text{int}} = 20 \text{ VDC}$
		$I \leq 22 \text{ mA}$	$I \leq 22 \text{ mA}$
		$I_{\text{max}} \leq 26 \text{ mA}$ (electronically limited)	$V_{0, \text{min}} = 14 \text{ V}$ at $I \leq 22 \text{ mA}$
		$V_{0, \text{min}} = 19 \text{ V}$ at $I \leq 22 \text{ mA}$	No HART®
Passive	-	No HART®	$V_0 = 24.1 \text{ V}$ $I_0 = 99 \text{ mA}$ $P_0 = 0.6 \text{ W}$ $C_0 = 75 \text{ nF} / L_0 = 0.5 \text{ mH}$
			No HART®
		$V_{\text{ext}} \leq 32 \text{ VDC}$	$V_{\text{ext}} \leq 32 \text{ VDC}$
		$I \leq 22 \text{ mA}$	$I \leq 22 \text{ mA}$
Passive	-	$I_{\text{max}} \leq 26 \text{ mA}$ (electronically limited)	$V_{0, \text{min}} = 4 \text{ V}$ at $I \leq 22 \text{ mA}$
		$V_{0, \text{min}} = 5 \text{ V}$ at $I \leq 22 \text{ mA}$	No HART®
		No HART®	$V_1 = 30 \text{ V}$ $I_1 = 100 \text{ mA}$ $P_1 = 1 \text{ W}$ $C_1 = 10 \text{ nF}$ $L_1 = 0 \text{ mH}$
			No HART®

FOUNDATION Fieldbus	
Description	Galvanically isolated according to IEC 61158
	Current consumption: 10.5 mA
	Permissible bus voltage: 9...32 V; in Ex application: 9...24 V
	Bus interface with integrated reverse polarity protection
	Link Master function (LM) supported
	Tested with Interoperable Test Kit (ITK) version 5.2
Function blocks	6 x analogue input (AI), 2 x integrator, 1 x PID, 1 x arithmetic
Output data	Volume flow, corr. volume flow, mass flow, molar mass, enthalpy flow, spec. enthalpy, density, flow speed, process temperature, process pressure, electronic temperature, velocity of sound (av.), gain (av.), SNR (av.), velocity of sound 1-3, gain 1-3, SNR 1-3

MODBUS	
Description	Modbus RTU, Master / Slave, RS485
Address range	1...247
Supported function codes	03, 04, 16
Broadcast	Supported with function code 16
Supported Baudrate	1200, 2400, 4800, 9600, 19200, 38400, 57600, 115200 Baud

Approvals and certificates

CE	
This device fulfils the statutory requirements of the relevant directives. The manufacturer certifies successful testing of the product by applying the conformity mark on the device.	
	For more information on the directives, standards and the approved certifications, please refer to the declaration of conformity supplied with the device or downloadable from the manufacturer's website.
Hazardous areas	
Non-Ex	Standard
Ex zone 1 - 2	For detailed information, please refer to the relevant Ex documentation. According to European directive 2014/34/EU / UK-Regulation 2016 No. 1107.
IECEX	OPTISONIC 8000: KIWA 17.0011 X
	GFC 300 F: KIWA 17.0001X
ATEX	OPTISONIC 8000: KIWA ATEX 17.0025 X
	GFC 300 F: KIWA ATEX 170002 X
Class 1, Div 2	cQPSus LR 1338-7R1
NEPSI	OPTISONIC 8000: GYJ181426X
	GFC 300: GYJ181425X
Other approvals and standards	
NAMUR	NE 21, 43, 53, 80
Protection category acc. to IEC 60529	Signal converter: Field (F) version, IP66/67, NEMA 4X/6
	All flow sensors: IP67, NEMA 6
Vibration resistance	IEC 60068-2-64
	f = 20...2000Hz, rms = 4.5g, t = 30min

2.2 Dimensions and weight

The OPTISONIC 8300 is available as weld-in or flanged version. The design of the tube of the flowmeter will be based on the specifications of the connecting piping. Detailed information for the dimensions and weights cannot be specified as they will vary with each application. The information below should therefore be regarded as indicative.

Please note size d, the required extra space for installation and maintenance of the transducers.

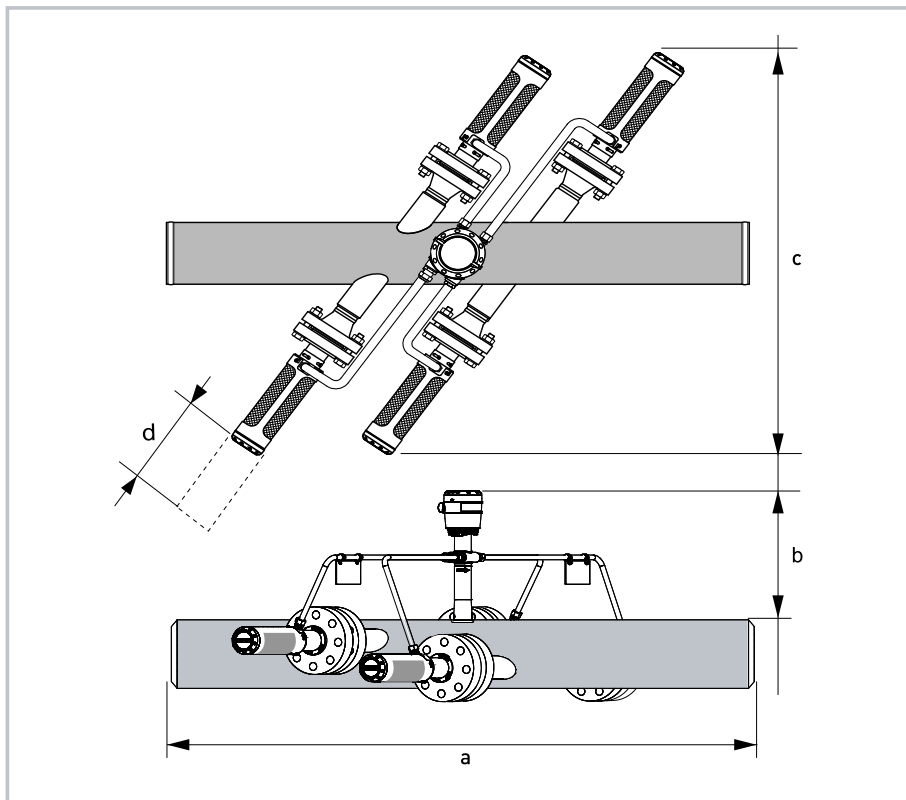

Figure 2-1: Top and front view of the OPTISONIC 8000

	[mm]	[inches]
a	DN100 / 4": 1000	DN100 / 4": 39.37
	DN150...600 / 6...24": 2000	DN150...600 / 6...24": 78.74
b	414	16.3
c	Transducer flange rating 600 lbs: 1184 + Di	600 lbs: 46.61 + Di
	Transducer flange rating 1500 lbs: 1205 + Di	1500 lbs: 47.44 + Di
d	80	3.15

Table 2-1: Dimensions of the OPTISONIC 8000 in mm and inches

+ Di = "add inner diameter of the sensor tube"

2.2.1 Converter housing

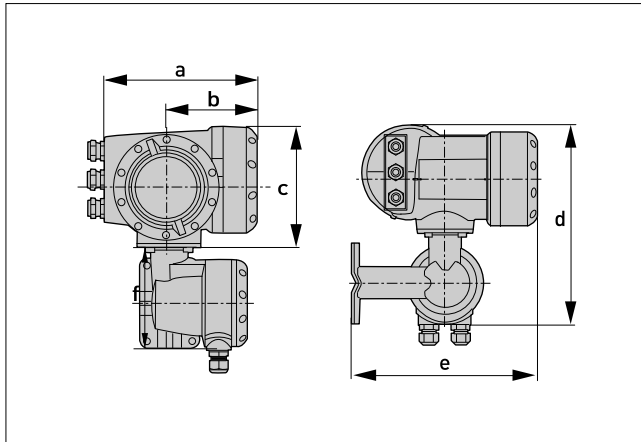

Figure 2-2: Field housing (F) - remote version.

Dimensions [mm]					Weight [kg]
a	b	c	d	e	
202	120	155	295.8	277	5.7

Table 2-2: Dimensions and weights in mm and kg

Dimensions [inches]					Weight [lb]
a	b	c	d	e	
7.75	4.75	6.10	11.60	10.90	12.60

Table 2-3: Dimensions and weights in inches and lb

2.2.2 Mounting plate of field housing

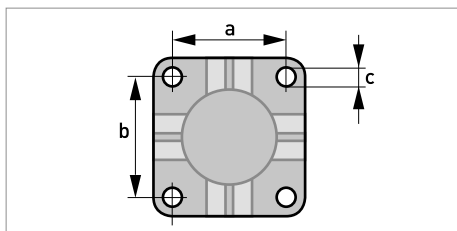

Figure 2-3: Dimensions for mounting plate of field housing

	[mm]	[inch]
a	72	2.8
b	72	2.8
c	Ø9	Ø0.4

Table 2-4: Dimensions in mm and inch

3.1 General notes on installation

Inspect the packaging carefully for damages or signs of rough handling. Report damage to the carrier and to the local office of the manufacturer.

Do a check of the packing list to make sure that you have all the elements given in the order.

Look at the device nameplate to ensure that the device is delivered according to your order. Check for the correct supply voltage printed on the nameplate.

3.2 Intended use

Responsibility for the use of the measuring devices with regard to suitability, intended use and corrosion resistance of the used materials against the measured fluid lies solely with the operator.

The manufacturer is not liable for any damage resulting from improper use or use for other than the intended purpose.

The **OPTISONIC 8300** is designed for the measurement of hot gases or superheated steam, 15°C/59°F overheated. Prevent unwanted contaminations which can disturb the acoustic signal. For superheated steam, the working area is defined (grey shaded) in the next figure.

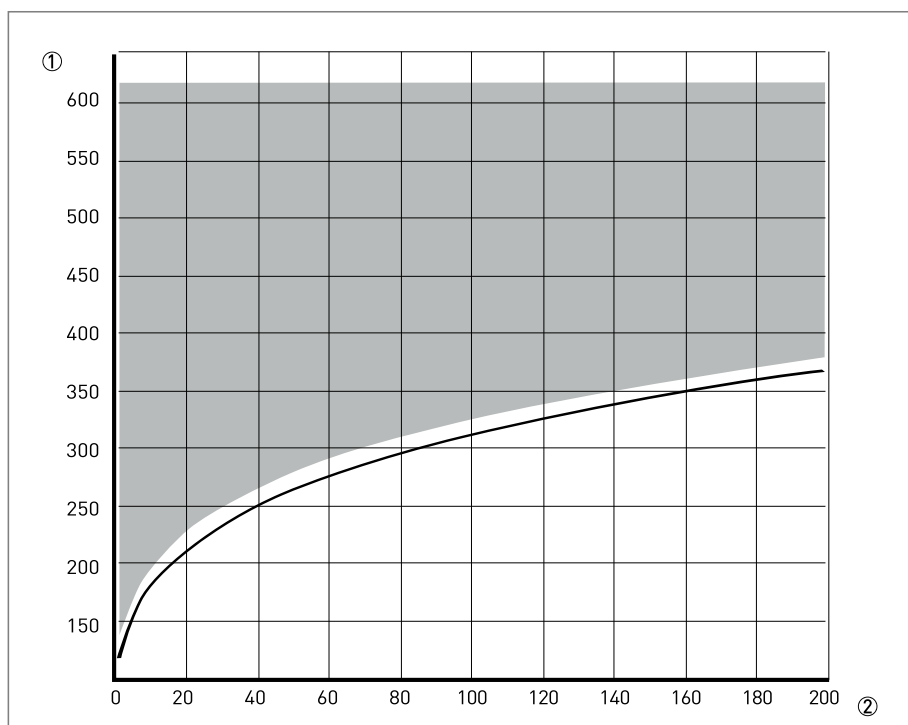

Figure 3-1: Steam saturation curve

- ① Temperature [°C]
- ② Pressure [Bara]

3.3 General requirements

The following precautions must be taken to ensure a reliable installation.

- *Make sure that there is adequate space on the sides.*
- *Protect the signal converter from direct sunlight and install a sunshade if necessary.*
- *Signal converters installed in control cabinets require adequate cooling, e.g. by fan or heat exchanger.*
- *Do not expose the signal converter to intense vibrations and mechanical shocks. The measuring devices are tested for a vibration/shock level as described in the chapter "Technical data".*

3.3.1 Vibration

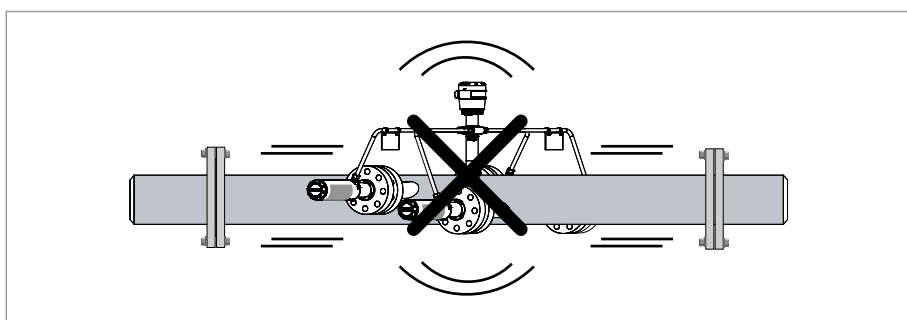

Figure 3-2: Prevent intense vibrations

In case of too many vibrations, please install supports on both sides of the flowmeter to minimize movement.

3.4 General requirements sensor

To secure the optimum functioning of the flowmeter, please note the following observations.

- Install the flow sensor in a horizontal position in a slightly descending line.
- Do not install the flow sensor in a lowered pipe section to avoid that water can collect in the measuring tube.
- Orientate the flow sensor such that the path of the acoustic signal is in the horizontal plane.

For exchanging the transducers, please keep a free space of 0.3 m / 11.81" around the transducer.

3.4.1 Inlet and outlet

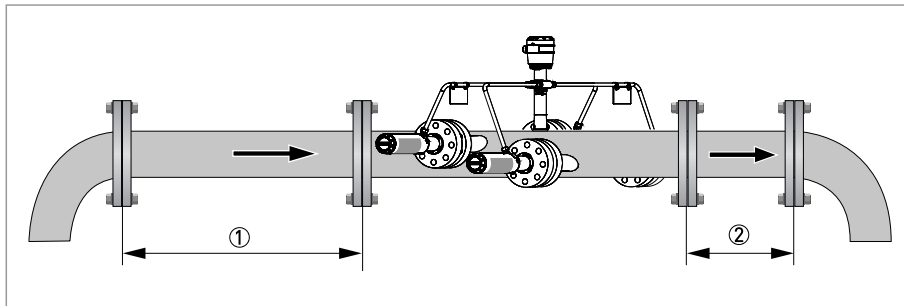

Figure 3-3: Recommended inlet and outlet

- ① Refer to chapter "Bends in 2 or 3 dimensions"
- ② ≥ 3 DN

3.4.2 Bends in 2 or 3 dimensions

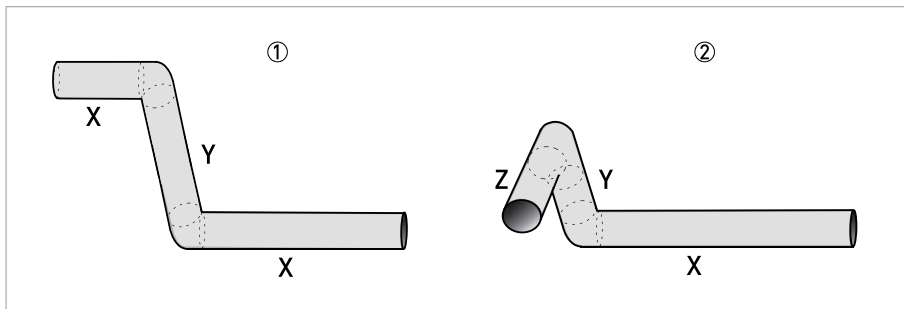

Figure 3-4: 2 and/or 3 dimensional bends upstream of the flowmeter

① 2 dimensions = X/Y

② 3 dimensions = X/Y/Z

Shorter inlet conditions (< 20 DN) are depending on the upstream pipe configuration.

*2 dimensional bends occur in a vertical **or** horizontal plane (X/Y) only, while 3 dimensional bends occur in both vertical **and** horizontal plane (X/Y/Z).*

3.4.3 T-section

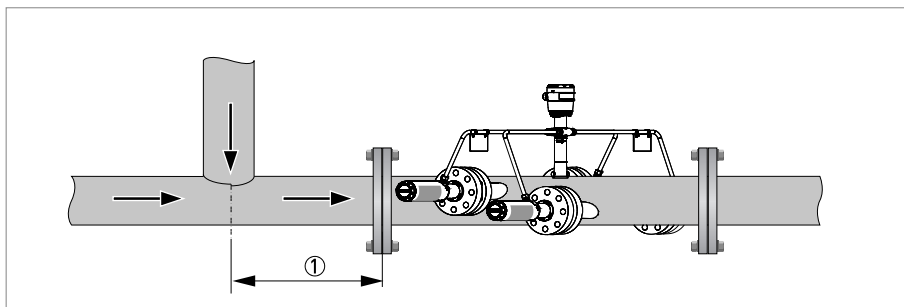

Figure 3-5: Distance behind a T-section

① ≥ 20 DN

3.4.4 Mounting position

- Install the flowmeter in horizontal position only in case of the presence of liquids and/or in steam applications.
- Horizontal or vertical installation position in case of dry gas.

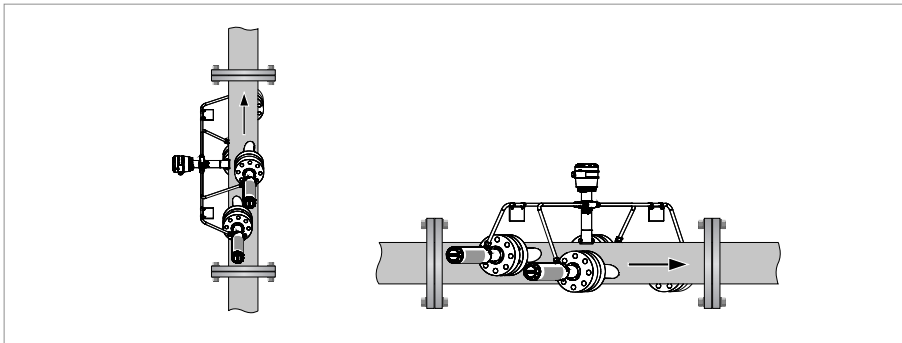

Figure 3-6: Horizontal or vertical installation

- In case of the presence of liquid or steam applications

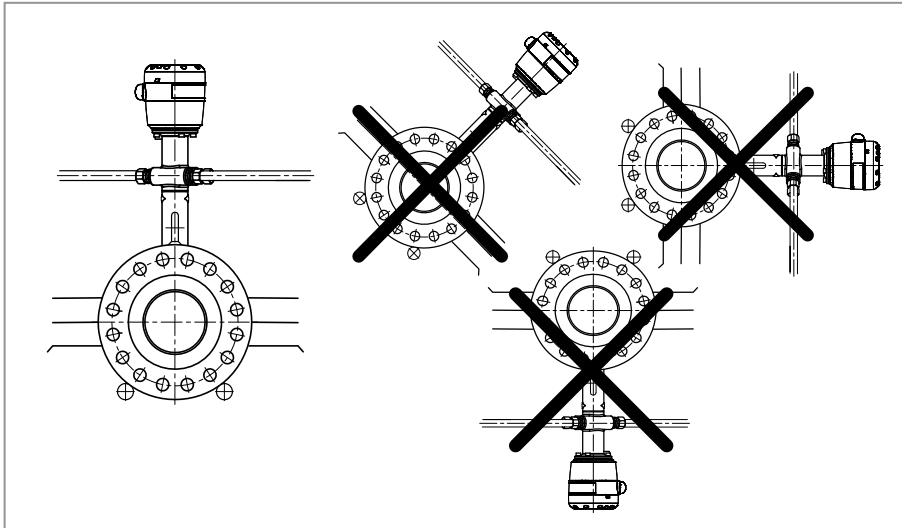

Figure 3-7: Mounting position

3.4.5 Flange deviation

Max. permissible deviation of pipe flange faces:

$$L_{max} - L_{min} \leq 0.5 \text{ mm} / 0.02''$$

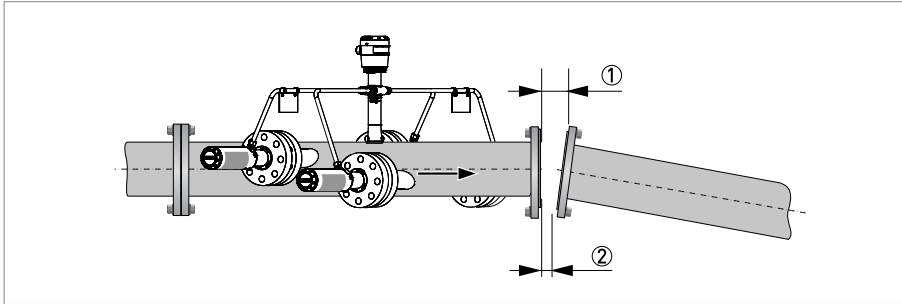

Figure 3-8: Flange deviation

- ① L_{max}
- ② L_{min}

3.4.6 Control valve

When a restriction (valve or reducer) is installed in the same pipeline with the flowmeter and noise is expected, please contact the manufacturer.

To prevent flow disturbances in the flowmeter a control valve is installed downstream of the flowmeter.

If a control valve is installed upstream of the flowmeter position, an extended straight inlet pipe (up to 50 DN) is recommended, depending on the process and control valve type.

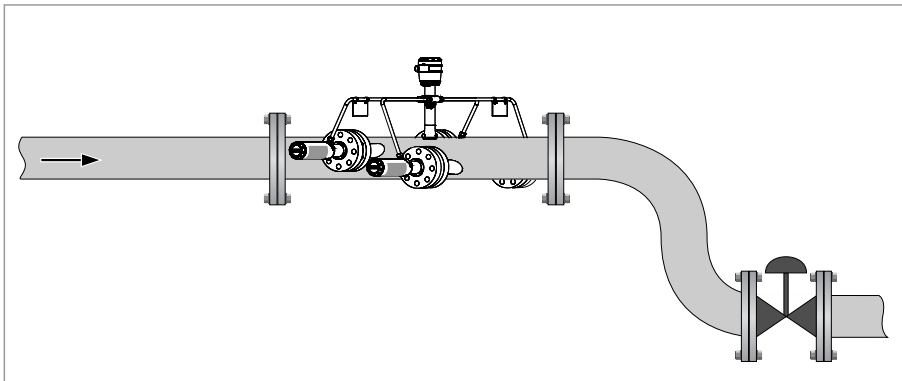

Figure 3-9: Recommended installation of the control valve

3.4.7 Thermal insulation

The flow sensor must be insulated to prevent humidity problems caused by condensation. Please make sure that the insulation is installed in accordance with the illustration below. In case of low-pressure steam in combination with low ambient temperature, electric heat tracing may be applied to prevent condensation and/or to reduce startup time.

Keep the transducers and connection box free of insulation to allow cooling by free convection. The transducers can reach a temperature of up to +200°C/+392°F!

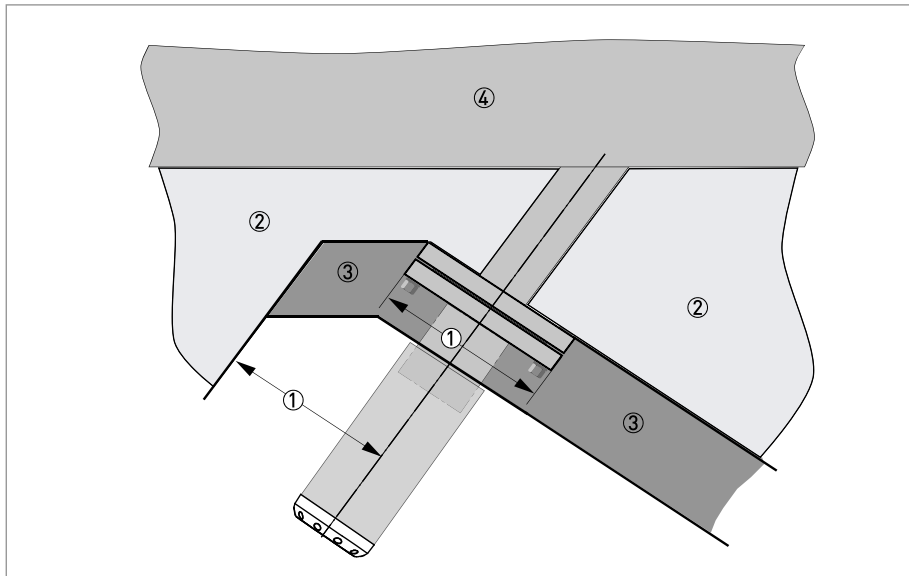

Figure 3-10: Thermal insulation

- ① Width of flange = free distance
- ② Standard insulation
- ③ Insulation for $T_{\text{process}} \leq +250^{\circ}\text{C}/+482^{\circ}\text{F}$
- ④ Sensor tube

For devices in a hazardous area, additional maximum temperature and insulation precautions apply. Please refer to the Ex documentation.

4.1 Safety instructions

*All work on the electrical connections may only be carried out with the power disconnected.
Take note of the voltage data on the nameplate!*

Observe the national regulations for electrical installations!

For devices used in hazardous areas, additional safety notes apply; please refer to the Ex documentation.

*Observe without fail the local occupational health and safety regulations.
Any work done on the electrical components of the measuring device may only be carried out by properly trained specialists.*

*Look at the device nameplate to ensure that the device is delivered according to your order.
Check for the correct supply voltage printed on the nameplate.*

4.2 Connection of signal cable to signal converter

The flow sensor is connected to the signal converter via one or two signal cables, with 2 inner Triax cables for the connection of one or two acoustic path(s). A flow sensor with one acoustic path has one cable. A flow sensor with two acoustic paths has two cables.

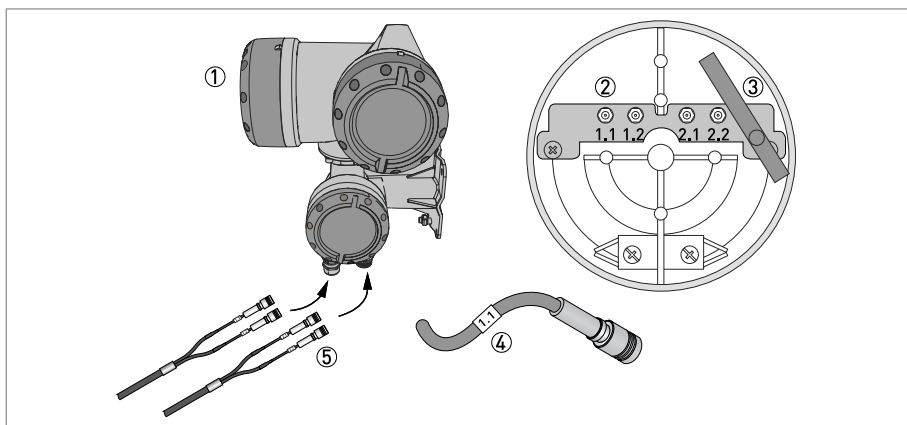

Figure 4-1: Connection of signal cable to signal converter

- ① Signal converter
- ② Open connection box
- ③ Tool for releasing connectors
- ④ Marking on cable
- ⑤ Insert cable [1 path flowmeter] or cables [2 path flowmeter] through cable glands

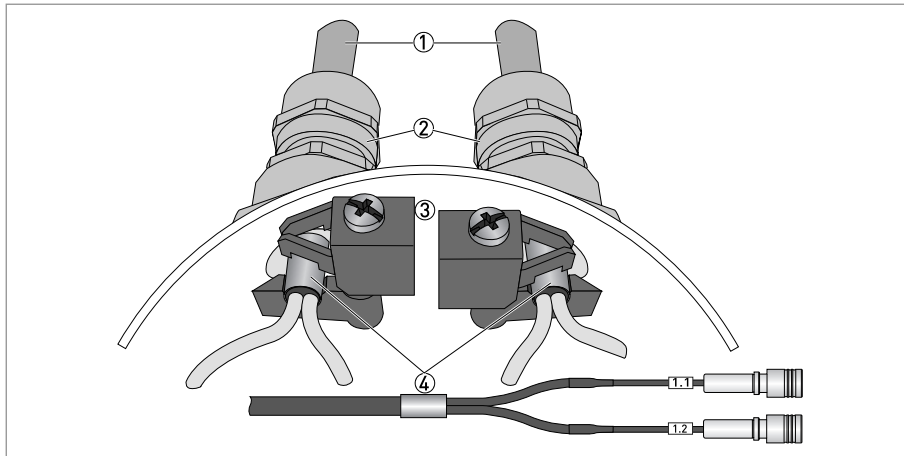

Figure 4-2: Clamp the cables on the shielding bush

- ① Cables
- ② Cable glands
- ③ Grounding clamps
- ④ Cable with metal shielding bush

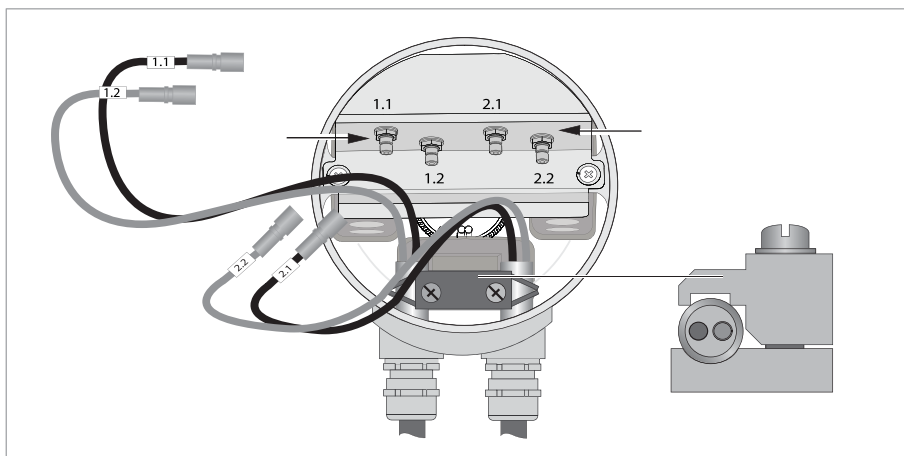

Figure 4-3: Connect the cables in the connection box of the sensor

Connect the cable on connector with similar numeral marking

4.3 Power supply connection

For devices used in hazardous areas, additional safety notes apply; please refer to the Ex documentation.

When this device is intended for permanent connection to the mains.

It is required (for example for service) to mount an external switch or circuit breaker near the device for disconnection from the mains. It shall be easily reachable by the operator and marked as the disconnecting the device for this equipment.

The switch or circuit breaker and wiring has to be suitable for the application and shall also be in accordance with the local (safety) requirements of the (building) installation (e.g. IEC 60947-1/-3)

The power terminals in the terminal compartments are equipped with additional hinged lids to prevent accidental contact.

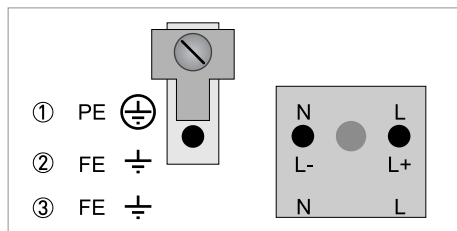

Figure 4-4: Power supply connection

- ① 100...230 VAC (-15% / +10%), 22 VA
- ② 24 VDC (-55% / +30%), 12 W
- ③ 24 VAC/DC (AC: -15% / +10%; DC: -25% / +30%), 22 VA or 12 W

Grounding of remote version

The device must be grounded in accordance with regulations in order to protect personnel against electric shocks.

For EMC reasons, connect the converter housing to a sufficiently low impedance grounding. If necessary, the external U-clamp (size M5) of the converter housing can be used for this purpose.

100...230 VAC (tolerance range for 100 VAC: -15% / +10%)

- Note the power supply voltage and frequency (50...60 Hz) on the nameplate.
- The protective ground terminal **PE** of the power supply must be connected to the separate U-clamp terminal in the terminal compartment of the signal converter

240 VAC + 5% is included in the tolerance range.

24 VDC (tolerance range: -55% / +30%)**24 VAC/DC (tolerance range: AC: -15% / +10%; DC: -25% / +30%)**

- Note the data on the nameplate!
- For measurement process reasons, a functional ground **FE** must be connected to the separate U-clamp terminal in the terminal compartment of the signal converter.
- When connecting to functional extra-low voltages, provide a facility for protective separation (PELV) (according to VDE 0100 / VDE 0106 and/or IEC 60364 / IEC 61140 or relevant national regulations)

4.4 Input and outputs, overview

4.4.1 Combinations of the inputs/outputs (I/Os)

This signal converter is available with various input/output combinations.

Basic version

- Has 1 current output, 1 pulse output and 2 status outputs/limit switches.
- The pulse output can be set as status output/limit switch and one of the status outputs as a control input.

Ex i version

- Depending on the task, the device can be configured with various input and output modules.
- Current outputs can be active or passive.
- Current inputs are active.
- Optionally available with Foundation Fieldbus.

Modular version

- Depending on the task, the device can be configured with various input and output modules.
- Current inputs and outputs can be active or passive.
- Optionally available with Foundation Fieldbus or RS 485 Modbus.

Bus systems

- The device allows intrinsically safe and non intrinsically safe bus interfaces in combination with additional modules.
- For connection and operation of bus systems, please note the supplementary documentation.

Ex option

- For hazardous areas, all of the input/output variants for the housing designs with a terminal compartment in the Ex d (pressure-resistant casing) or Ex e (increased safety) versions can be delivered.
- For connection and operation of Ex devices, note the supplementary instructions.

4.4.2 Description of the CG number

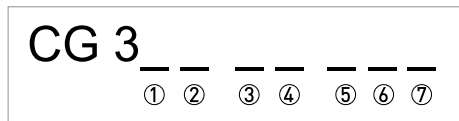

Figure 4-5: Marking (CG number) of the electronics module and input/output variants

- ① ID number: 6
- ② ID number: 0 = standard
- ③ Power supply option
- ④ Display (language versions)
- ⑤ Input/output version (I/O)
- ⑥ 1st optional module for connection terminal A
- ⑦ 2nd optional module for connection terminal B

The last 3 digits of the CG number (⑤ , ⑥ and ⑦) indicate the assignment of the terminal connections. Please see the following examples.

Examples for CG number

CG 360 11 100	100...230 VAC & standard display; basic I/O: I_a or I_p & S_p/C_p & S_p & P_p/S_p
CG 360 11 7FK	100...230 VAC & standard display; modular I/O: I_a & P_N/S_N and optional module P_N/S_N & C_N
CG 360 81 4EB	24 VDC & standard display; modular I/O: I_a & P_a/S_a and optional module P_p/S_p & I_p

Abbreviation	Identifier for CG no.	Description
I_a	A	Active current output
I_p	B	Passive current output
P_a / S_a	C	Active pulse output, frequency output, status output or limit switch (changeable)
P_p / S_p	E	Passive pulse output, frequency output, status output or limit switch (changeable)
P_N / S_N	F	Passive pulse output, frequency output, status output or limit switch according to NAMUR (changeable)
C_a	G	Active control input
C_p	K	Passive control input
C_N	H	Active control input to NAMUR Signal converter monitors cable breaks and short circuits according to EN 60947-5-6. Errors indicated on LC display. Error messages possible via status output.
$II n_a$	P	Active current input (for Modular I/O)
$II n_p$	R	Passive current input (for Modular I/O)
$2 \times II n_a$	5	Two active current inputs (for Ex i I/O)
-	8	No additional module installed
-	0	No further module possible

Table 4-1: Description of abbreviations and CG identifier for possible optional modules on terminals A and B

4.4.3 Fixed, non-alterable input/output versions

This signal converter is available with various input/output combinations.

- The grey boxes in the tables denote unassigned or unused connection terminals.
- In the table, only the final digits of the CG no. are depicted.
- Connection terminal A+ is only operable in the basic input/output version.

CG no.	Connection terminals								
	A+	A	A-	B	B-	C	C-	D	D-

Basic I/Os (standard)

1 0 0		I_p + HART® passive ①	S_p / C_p passive ②	S_p passive	P_p / S_p passive ②
		I_a + HART® active ①			

Ex i I/Os (option)

2 0 0				I_a + HART® active	P_N / S_N NAMUR ②
3 0 0				I_p + HART® passive	P_N / S_N NAMUR ②
2 1 0		I_a active	P_N / S_N NAMUR C_p passive ②	I_a + HART® active	P_N / S_N NAMUR ②
3 1 0		I_a active	P_N / S_N NAMUR C_p passive ②	I_p + HART® passive	P_N / S_N NAMUR ②
2 2 0		I_p passive	P_N / S_N NAMUR C_p passive ②	I_a + HART® active	P_N / S_N NAMUR ②
3 2 0		I_p passive	P_N / S_N NAMUR C_p passive ②	I_p + HART® passive	P_N / S_N NAMUR ②
2 3 0		$I I n_a$ active	P_N / S_N NAMUR C_p passive ②	I_a + HART® active	P_N / S_N NAMUR ②
3 3 0		$I I n_a$ active	P_N / S_N NAMUR C_p passive ②	I_p + HART® passive	P_N / S_N NAMUR ②
2 4 0		$I I n_p$ passive	P_N / S_N NAMUR C_p passive ②	I_a + HART® active	P_N / S_N NAMUR ②
3 4 0		$I I n_p$ passive	P_N / S_N NAMUR C_p passive ②	I_p + HART® passive	P_N / S_N NAMUR ②

① Function changed by reconnecting

② Changeable

4.4.4 Alterable input/output versions

This signal converter is available with various input/output combinations.

- The grey boxes in the tables denote unassigned or unused connection terminals.
- In the table, only the final digits of the CG no. are depicted.
- Term. = (connection) terminal

CG no.	Connection terminals								
	A+	A	A-	B	B-	C	C-	D	D-

Modular IOs (option)

4 __		max. 2 optional modules for term. A + B	I _a + HART® active	P _a / S _a active ①
8 __		max. 2 optional modules for term. A + B	I _p + HART® passive	P _a / S _a active ①
6 __		max. 2 optional modules for term. A + B	I _a + HART® active	P _p / S _p passive ①
B __		max. 2 optional modules for term. A + B	I _p + HART® passive	P _p / S _p passive ①
7 __		max. 2 optional modules for term. A + B	I _a + HART® active	P _N / S _N NAMUR ①
C __		max. 2 optional modules for term. A + B	I _p + HART® passive	P _N / S _N NAMUR ①

FOUNDATION Fieldbus (option)

E __		max. 2 optional modules for term. A + B	V/D+ (2)	V/D- (2)	V/D+ (1)	V/D- (1)
------	--	---	----------	----------	----------	----------

Modbus (option)

G __ ②		max. 2 optional modules for term. A + B		Common	Sign. B (D1)	Sign. A (D0)
H __ ③		max. 2 optional modules for term. A + B		Common	Sign. B (D1)	Sign. A (D0)

① Changeable

② Not activated bus terminator

③ Activated bus terminator

Please fill in this form and fax or email it to your local representative.
Please include a sketch of the pipe layout as well, including the X, Y, Z dimensions.

Customer information:

Date:	
Submitted by:	
Company:	
Address:	
Telephone:	
Fax:	
E-mail:	

Flow application data:

Reference information (name, tag etc):	
New application Existing application, currently using:	
Measurement objective:	
Flow application data / Medium	
Gas type / composition:	
CO ₂ content:	
CH ₄ content:	
H ₂ S content:	
Moisture content:	
Density or molecular weight:	
Velocity of sound:	
Flow rate	
Normal:	
Minimum:	
Maximum:	
Temperature	
Normal:	
Minimum:	
Maximum:	
Pressure	
Normal:	
Minimum:	
Maximum:	

Piping details

Nominal pipe size:	
Inner / outer diameter:	
Wall thickness / schedule:	
Pipe material:	
Straight inlet / outlet section (DN):	
Upstream situation (elbows, valves, pumps):	
Type of valve or reducer:	
Pressure drop over the valve or reducer:	
Position of the valve or reducer compared to flowmeter:	
Flow orientation (vertical up / horizontal / vertical down / other):	

Environment details

Corrosive atmosphere:	
Sea water:	
High humidity (% R.H.)	
Nuclear (radiation):	
Hazardous area:	
Additional details:	

Hardware requirements:

Accuracy requested (percentage of rate):	
Power supply (voltage, AC/DC):	
Analogue output (4..20 mA)	
Pulse (specify minimum pulse width, pulse value):	
Digital protocol:	
Accessories:	

KROHNE – Products, Solutions and Services

- Process instrumentation for flow, level, temperature, pressure measurement and process analytics
- Flow metering, monitoring, wireless and remote metering solutions
- Engineering, commissioning, calibration, maintenance and training services

Head Office KROHNE Messtechnik GmbH
Ludwig-Krohne-Str. 5
47058 Duisburg (Germany)
Tel.: +49 203 301 0
Fax: +49 203 301 10389
info@krohne.de

The current list of all KROHNE contacts and addresses can be found at:
www.krohne.com

