

Max-Air

A Brand of Max-Air Technology.

Quarter-Turn Rack & Pinion Actuators

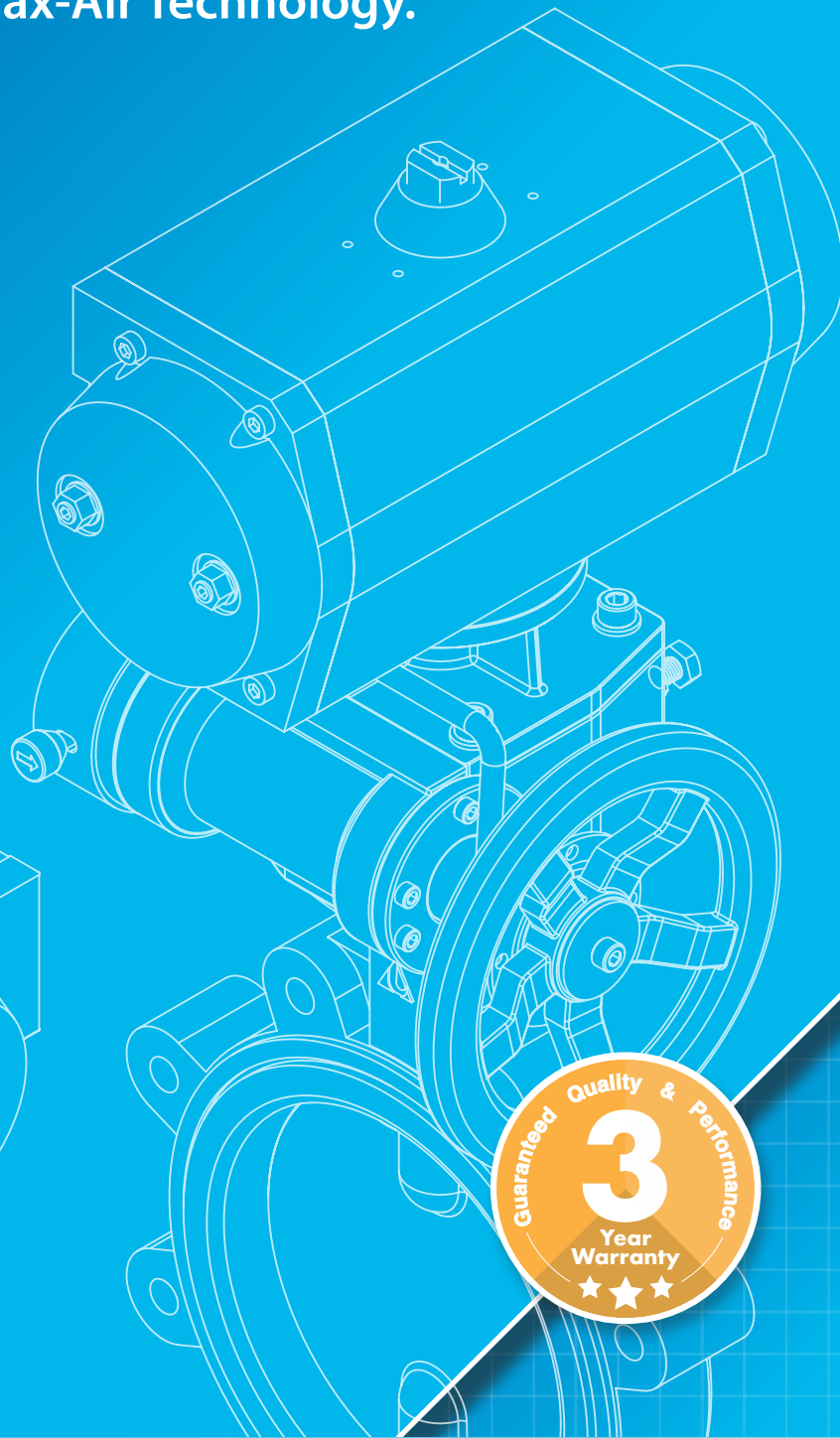
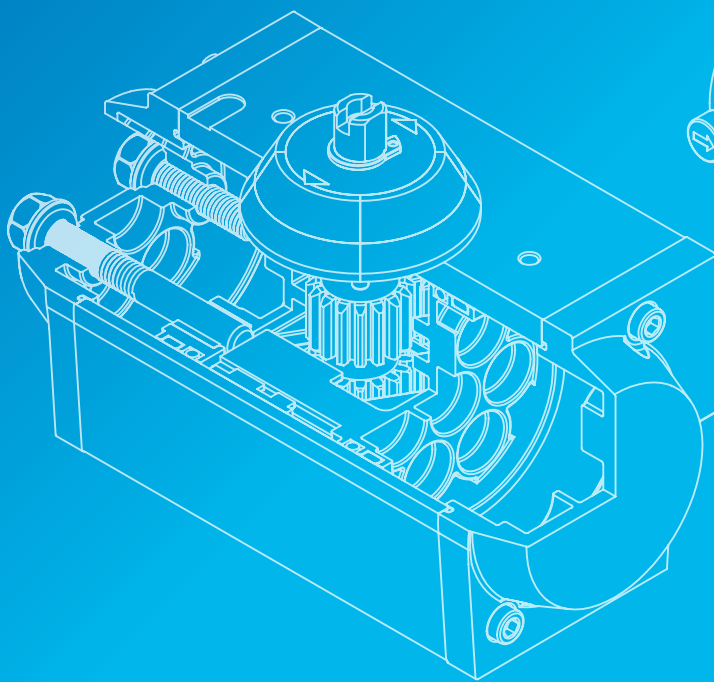

MT Series Technical Brochure

Max-Air Technology Inc. | Rotary Actuators & Valve Automation Solutions

MT Series Rack & Pinion Actuators

Air powered 90° rotary actuators for precise action and reliable long-life operation.

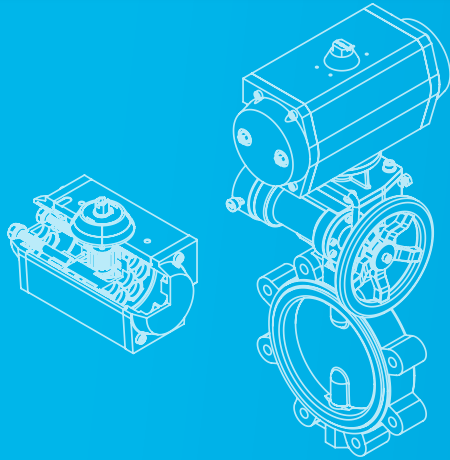

MT Series rack & pinion pneumatic actuators continue the Max-Air tradition of easy integration, flexible customization, and reliable operation. Features include two ISO bolt circle patterns drilled directly in the body, NAMUR standard mounting for accessories, and our patented $\pm 10^\circ$ adjustment for the open/closed positions, all backed by the best unlimited cycle life warranty.

MT Series Part # Builder

AB.	C.	D.	E.	F.	GH		
MT	36.	DA.	F07-F10.	CH22	LT	FO	-

Example Part # **MT36.F07-F10.CH22.LT.FO**

EXAMPLE DESCRIPTION: MT SERIES (ALUMINUM), SIZE 36, DOUBLE ACTING, F07-F10 MOUNTING, 22MM DSQ OUTPUT DRIVE, LOW TEMP SEALS, REVERSE ROTATION

A - SERIES	B - SIZE			C - CONFIGURATION	
MT = Aluminum	04,	26	56	DA = Double-Acting	S7x5 = 7+5 Springs
ENP.MT = Electroless Nickel Plated	12	31	61	S2 = 2+2 Springs	S7 = 7+7 Springs
LMC.MT = LockMesh Coated	08	36	66	S3 = 3+3 Springs	S8 = 8+8 Springs
EPOXY.MT = Epoxy Coated	16	41	71	S4 = 4+4 Springs	
Omit if N/A	17	46	76	S5 = 5+5 Springs	
	21	51		S6 = 6+6 Springs	

D - MOUNTING	E - OUTPUT DRIVE	F - SPECIAL SEALS	G - ROTATION	H - TRAVEL STOPS
F04	CH9 = 9mm DSQ	SLT = Super Low Temp	(Omit) = Standard	(Omit) = Standard
F03 - F05	CH11 = 11mm DSQ	LT = Low Temp	FO = Reverse	M = Max Extended
F04 - F07	CH14 = 14mm DSQ	(Omit) = Standard	C = Standard Parallel	Z = Zero Extended
F05 - F07	CH17 = 17mm DSQ	HT = High Temp	D = Reverse Perpendicular	B = Set Extended
F07 - F10	CH22 = 22mm DSQ	LTB = Low Temp BUNA		
F10 - F12	CH27 = 27mm DSQ			
F10 - F14	CH36 = 36mm DSQ			
F16	CH46 = 46mm DSQ			
	Call for keyway & DD options.			

PINION OPTIONS

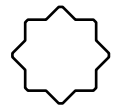

DOUBLE-SQUARE
(ISO STANDARD)



DOUBLE-D
(OPTIONAL)



KEYWAY
(OPTIONAL)

*Note: 1) Not all combinations available, and special solutions not shown are possible. Please call factory for details. 2) Max-Air Technology reserves the right to change or modify products without prior notice & without incurring any obligation to make such changes on products previously or subsequently sold.

CODE	SEALS	TEMPERATURE RANGE
SLT	SUPER LOW TEMP. (FVMQ)	-67°F (-55°C) to 250°F continuous & 300°F cyclic
LT	LOW TEMP. (SILICONE)	-49°F (-45°C) to 250°F continuous & 300°F cyclic
STD	STANDARD (BUNA-N)	-4°F (-20°C) to 176°F (80°C)
HT	HIGH TEMP. (VITON)	-10°F (-23°C) to 250°F continuous & 300°F cyclic
LTB	LOW TEMP. BUNA	-40°F (-40°C) to 212°F (100°C)





Table of Contents

Pg - Description

[02 - Part Number Builder](#)

[03 - Table of Contents](#)

[04 - Features & Benefits](#)

[08 - Reference Tables & Variations](#)

[10 - Double Acting: Torques, Sizing, & Configuration](#)

[11 - Spring Return: Torques, Sizing, & Configuration](#)

[14 - Exploded Views, Materials, & Dimensions](#)

[23 - Standards, Certifications & Approvals](#)



3-YEAR LIMITED WARRANTY

Max-Air Technology Inc. | The Best Way to Automate Your Process

Max-Air Technology provides the following warranty regarding its products. THE WARRANTY STATED HEREIN IS EXPRESSLY IN LIEU OF ALL OTHER WARRANTIES AND REPRESENTATIONS, EXPRESSED OR IMPLIED, OR STATUTORY, INCLUDING, WITHOUT LIMITATION, THE IMPLIED WARRANTY OF FITNESS FOR A PARTICULAR PURPOSE. Max-Air Technology warrants its products shall be delivered free from defects in materials and workmanship when these products are used for the purpose for which they were designed and manufactured. Max-Air Technology does not warrant its products against chemical or stress corrosion or against any other failure other than from defects in materials or workmanship. The applicable warranty period is dependent on the clearly identified brand labeling.

The warranty period for Max-Air, Max-Electric, Delta T, and Sesto Valves brand labeled products is for thirty-six (36) months from the delivery date to the Purchaser.

Any claims regarding this warranty must be in writing and received by Max-Air Technology before the last effective date of the warranty period, failing which this warranty shall expire. Upon Max-Air Technology's receipt of a warranty claim, Max-Air Technology reserves the right to inspect the product(s) in question at either the field location or at Max-Air Technology manufacturing plant. If, after inspection of the product(s) in question, Max-Air Technology determines that the Purchaser's claim is covered by this warranty, Max-Air Technology's sole liability and the Purchaser's sole remedy under this warranty is limited to the refunding of the purchase price or repair or replacement thereof at Max-Air Technology's option. Warranty repair, replacement or re-performance by Seller shall not extend or renew the applicable warranty period. Max-Air Technology will not be liable for any repairs, labor, material or other expenses that are not specifically authorized in writing by Max-Air Technology, and in no event shall Max-Air Technology be liable for any direct, indirect or consequential damages arising out of any defect from any cause whatsoever. If any Max-Air Technology product is modified or altered at any location other than Max-Air Technology – Wentzville (Missouri) or Max-Air Technology – Agrate Brianza (MB) ITALY without the express written authorization of Max-Air Technology, it is expressly not covered by this warranty. The warranties and remedies are conditioned upon (a) proper storage, installation, use, operation, and maintenance of products, (b) Purchaser keeping accurate and complete records of operation and maintenance during the warranty period and providing Max-Air Technology access to those records, and (c) modification or repair of products only as authorized by Max-Air Technology in writing. Failure to meet any such conditions renders the warranty null and void. Max-Air Technology is not responsible for normal wear and tear. The warranty for such products shall be subject only to the warranty relief, if any, provided by the suppliers and/or manufacturers of such products.

Features & Benefits

Air powered 90° rotary actuators for precise action and reliable long-life operation.

The Core of Max-Air Technology

Back in 1999, Max-Air Technology entered the market with rack and pinion actuators featuring a unique, patented design. Today, Max-Air's core product line-up builds on this proven design with the most extensive rack and pinion actuator offering in the world. Alternate housing and seal materials, finishes, coatings, 90° through 180° rotations, and industry best +/-10° travel stops ensure that Max-Air offers the perfect solution.

The MT Series rack & pinion pneumatic actuators continue the Max-Air tradition of easy integration, flexible customization, and reliable operation. Features include two ISO bolt circle patterns drilled directly in the body, NAMUR standard mounting for accessories, and our patented ±10° adjustment for the open/closed positions, all backed by the best unlimited cycle life warranty.

Features:

- Compact Rack and Pinion Design
- 3D Models Available for All 17 Sizes
- Direct ISO 5211 Standard Valve Mounting
- Direct NAMUR Accessory Mounting
- Anti-Blowout Bi-Directional Pinion Retention
- High Visibility Open/Closed Beacon
- Pre-Loaded Spring Cartridges
- Double-Acting (Air-to-Air) Operation
- Spring-Return (Air-to-Spring), Fail-Close or Fail-Open
- Standard (CCW open) or Reverse (CW open) Rotation
- Patented Dual Travel Stop Design ±10° Adjustment
- Designed for High Cycles 1,000,000+
- Unlimited Cycle Life Warranty

Options:

- Female Double-D and Keyed Pinions
- T-Port & L-Port indicators for multiport applications
- Extended travel stops for greater stroke adjustment
- ENP, Polyamide Epoxy, & LockMesh™ coatings
- Alternative Operating Media (Water, Oil, Inert Gas)
- High and Low Temperature Options
- Fast Open / Fast Close Options

Temperature Seal Options

Available for MT Series and SS Series Actuators



Seals	Temperature Range
Super Low Temp. (FVMQ)	-67°F (-55°C) to 250°F continuous & 300°F cyclic
Low Temp. (Silicone)	-49°F (-45°C) to 250°F continuous & 300°F cyclic
Standard (BUNA-N)	-4°F (-20°C) to 176°F (80°C)
High Temp. (VITON)	-10°F (-23°C) to 250°F continuous & 300°F cyclic
Low Temp. Buna	-40°F (-40°C) to 212°F (100°C)



Specifications:

Rotation	90 Degrees ±10° Adjustment (MT12-MT76) Spring Return or Double Acting
Torque Range	Up to 47,250 in-lbs (DA) & 22,746 in-lbs (SR)
Ambient Temp.	-4°F to 176°F Standard (-67°F Low, 300°F High)
Housing	Anodized Aluminum
Pinion	Nickel Plated Carbon Steel
Endcaps & Pistons	Epoxy Coated Die Cast Aluminum
Fasteners	AISI 304 Stainless Steel
Seals	BUNA-N Standard (high & low temp options)
Skates & Wear Bearings	Technopolymer
Spring Cartridges	Epoxy Coated Steel w/ Technopolymer Cartridge
Operating Pressure	40 to 120 PSI
Max Pressure Rating	150 PSI
Operation Media	Gas or Low Pressure Hydraulic Fluid
Mounting	ISO 5211, NAMUR VDI/VDE 3845
Additional Options	DD Pinions, Fast Acting, Extended Travel Stops



*See **SS Series** for nearly identical Actuator in Stainless Steel

*Optional Finishes/Coatings Available like **Lock Mesh®**, **Epoxy Coating**, and **ENP** (Electroless Nickel Plated)

17 Different Sizes Available

With 50% more actuator sizes than the competition, the MT Series can better match valve torques and reduce oversizing. This saves valuable space, reduces overall weight, and eliminates unnecessary cost.

MT Series Technical Brochure

Max-Air Technology Inc. | Rotary Actuators & Valve Automation Solutions



maxairtech.com

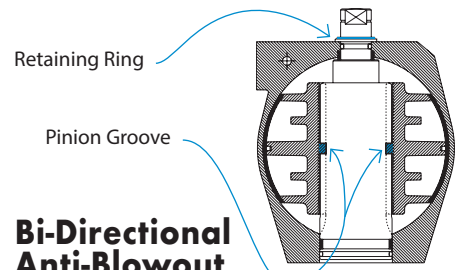
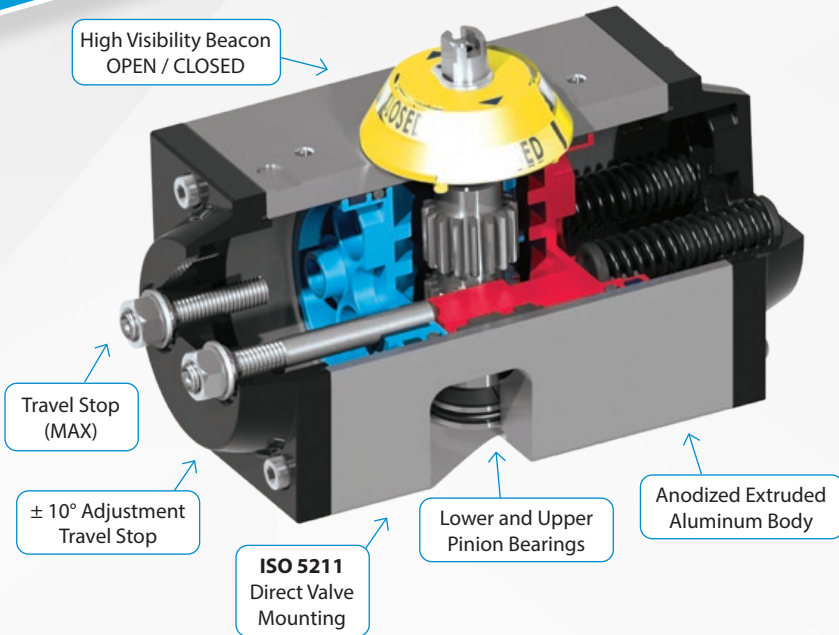

Bi-Directional Anti-Blowout Retention System

The anti-blowout system of the pinion is ensured thru a double protection: both with an upper c-clip and two keyways casted on the pistons. In case of unusual downward movement of the pinion, the keyways will interfere with the grooves on the pinion and therefore stopping it.

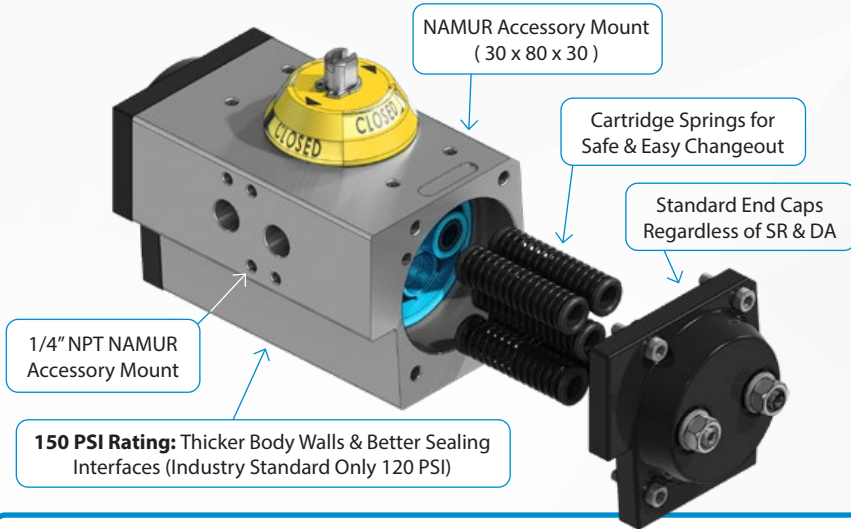

Special Finish/Coatings

Available for MT Series Actuators.

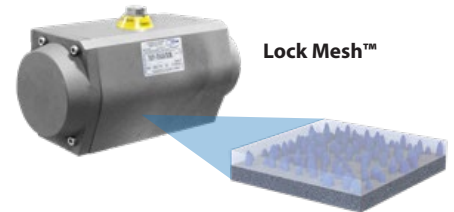

LockMesh®, ENP, Epoxy

Aluminum corrosion resistance can be enhanced by epoxy coating, electro-less nickel plating, or Max-Air's exclusive LockMesh™ SS+PTFE coating. See page 6 for options compared.

Patented Dual Travel Stop Design

Standard on MT Series, SS Series, & UT Series Rack and Pinion Actuators

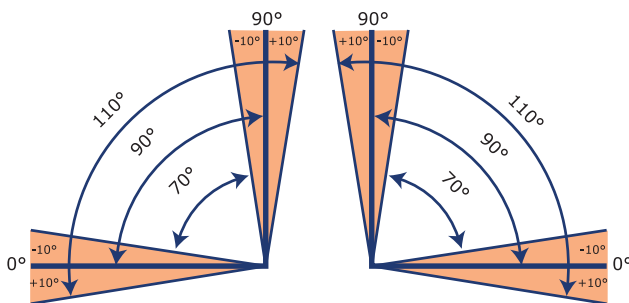

STANDARD +/- 10° ADJUSTMENT OPEN & CLOSE

- Travel adjustable from 70° up to 110° rotation
- Angle seating capable with standard travel stops
- Compensates for slop in valve/actuator/coupling interface
- Typical industry standard is +/- 3°

LINEAR PISTON STOPS, BOTH ON SAME SIDE

- Easier adjustment for tighter space requirements
- Clearly marked "0" (Closed) and "MAX" (Open)
- Extremely high repeatability, no hysteresis
- Allows for greater travel adjustment than rotary cam stops
- Lower degrees per turn allows for more precision
- No uneven side loading or wear on the pinion

OPTIONAL EXTENDED TRAVEL STOPS

- Close adjustment up to 30° or more from full closed
- Open adjustment up to full actuator stroke (90° from open)
- Fail-safe applications where full close shutoff is not desired
- Special rotations where travel is much less than 90° (i.e. 45°, 60°)

High Cycle Life Design

Precision Honed Bore, High Cycle Wear Bearings,, Rugged Tooth Design



High Cycle Wear Bearings

High performance technopolymer bearings eliminate metal-to-metal sliding contact.

- Low friction, Large contact area
- 2 axial + 1 thrust bearing for pinion
- 2 axial bearings per piston, plus zero travel stop bearing

SIL3
Safety Integrity Level

Designed & Tested
1,000,000+ Cycles

MT Series actuators have a holistic high-cycle life design. To maximize actuator life and take full advantage of the warranty, Max-Air always recommends clean, dry air for operation and regular preventative maintenance. Rebreathers are readily available and also recommended to keep dirty environmental air out of the internals and prolong the life of seals and grease. The Max-Air MT Series design is tested and verified to over 1,000,000+ cycles under full rated load.

Materials, Coatings, & Special Finishes Compared

Precision Honed Bore

This high end feature, is not industry standard. A uniform bore surface provides consistent seal contact and compression. Micro-scratches provide even lubrication which minimizes the “wiping” effect. Our Honed Bore will provide consistent long-life operation with multiple seal materials and greases.

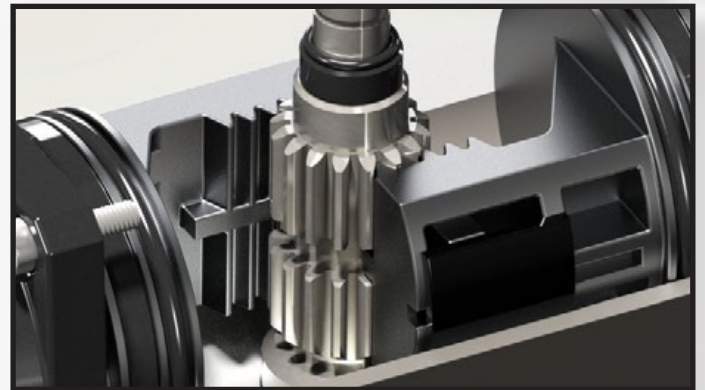
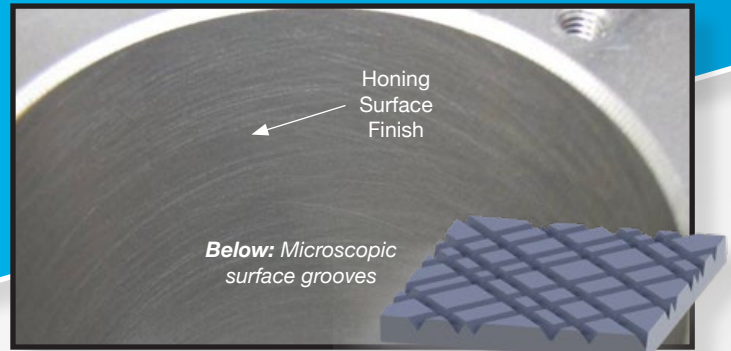

Rugged Tooth Rack and Pinion Design

The MT Series exclusive rack and pinion tooth design was created to better withstand valve “slamming” and other dynamic forces. After years of research and development, Max-Air was able to optimize a tooth profile for higher strength and resiliency, but with minimal backlash.

Increased Corrosion Resistance & Relative Cost

Materials/Coatings w/ Properties & Limitations

Options	Aluminum: Hard Anodized (Standard)	Aluminum: Anodized w/ Polyamide Epoxy Coating	Aluminum: Electroless Nickel Infused	Aluminum: Teflon Infused SS Mesh “Lock Mesh™” Coating	Stainless Steel: ASTM A351 Grade CF8M
Properties	Good general corrosion properties in most “natural” environments with pH from 4.5 to 8.5. Good resistance to salt air environments. The coating is extremely hard and resistant to abrasion.	The epoxy coating is relatively thick, which creates a barrier against many of the chemicals which anodizing alone cannot adequately resist. It will resist more acidic or basic environments than anodizing alone.	Uniformly thick coating with essentially no porosity and a reasonably high hardness. The coating is pure, tough, hard, and resistant to many types of corrosion media.	This coating provides complete surface coverage and exhibits excellent corrosion resistance properties in a wide variety of applications. In addition, it is FDA approved for food contact.	304 and 316 stainless steel are the most commonly used alloys. Both have good corrosion resistance but 316 is generally considered superior, however more expensive.
Performance Limitations	Highly acidic or basic environments will break down the coating.	Good general corrosion resistance, particularly in salt or alkaline environments. Limited resistance to acids. Surface chalking will occur when exposed to UV radiation. Also suitable for low concentrations of caustic washdown solutions.	The coating will provide enhanced corrosion protection in very acidic environments but will not withstand attack from strong alkaline media. Also suitable for low to medium concentrations of caustic washdown solutions.	These coatings are resistant to any environment into which an actuator would be installed. Provided the integrity of the surface is intact, the coating can resist a broad array of chemical environments at temperatures ranging from sub- zero to 350° F.	Although stainless steel does offer enhanced corrosion resistance, it also is dramatically higher in both cost and weight. The weight differential will often necessitate the use of special support bracketry. Corrosion resistance is superior.

MT Series Technical Brochure

Max-Air Technology Inc. | Rotary Actuators & Valve Automation Solutions



maxairtech.com

Mounting Reference

SIZE	Drive (mm)	Drive (in)	Standard ISO Pattern	Optional Pattern
MT04	9	0.354	F03	-
MT12	11	0.433	F03/F05	F04
MT08	11	0.433	F03/F05	F04
MT16	14	0.551	F05/F07	F04/F07
MT17	14	0.551	F05/F07	-
MT21	17	0.670	F05/F07	-
MT26	17	0.670	F05/F07	-
MT31	17	0.670	F05/F07	-
MT36	22	0.866	F07/F10	-
MT41	22	0.866	F07/F10	-
MT46	22	0.866	F07/F10	-
MT51	27	1.063	F10/F12	-
MT56	27	1.063	F10/F12	-
MT61	36	1.417	F10/F14	F10/F12
MT66	36	1.417	F10/F14	F10/F12
MT71	46	1.811	F16	F14
MT76	46	1.811	F16	-

Weights & Air Consumption

SIZE	Double Acting		Spring Return	
	Weight lbs	Air Consumption (cu-in)	Weight lbs	Air Consumption (cu-in)
MT04	1.06	4.03	NA	NA
MT12	2.00	13.50	2.18	8.00
MT08	2.76	15.26	3.00	6.10
MT16	3.52	25.60	3.94	11.20
MT17	4.22	34.30	4.75	15.60
MT21	5.17	44.40	6.00	18.10
MT26	7.15	68.70	8.30	30.00
MT31	9.13	88.90	10.74	40.60
MT36	14.60	153.10	17.80	75.00
MT41	17.20	190.60	20.90	100.00
MT46	24.20	275.00	29.90	115.60
MT51	35.30	425.00	42.00	181.30
MT56	44.10	565.50	53.80	256.30
MT61	61.50	881.30	83.10	343.80
MT66	84.50	1037.50	105.60	443.80
MT71	147.30	1694.00	182.90	600.00
MT76	179.90	1963.00	216.10	731.00

Extended Travel Stops

Position Adjustment :

Closed +30° or more
or Open up to full stroke

Potential Applications:

Fail-safe applications where full close shutoff is not desired or
Special rotations where travel is much less than 90° (i.e. 45°, 60°)



Beacon Options



Red/Green



T-Port



L-Port

Reference Tables & Variations

Standard Rotation, Reverse Rotation, Standard Parallel, and Reverse Perpendicular Variations

Mounting Variations

Supply Air
Exhaust to Atmosphere

Standard Rotation

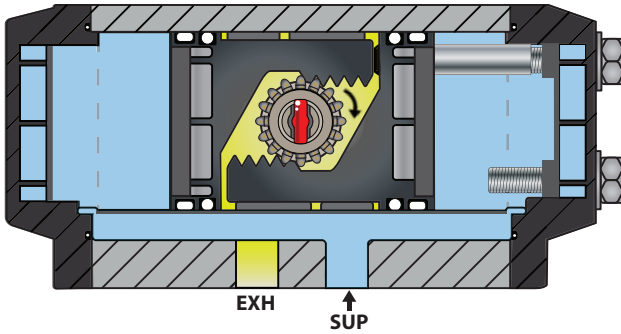

**(Fail CW Perpendicular)
Closed Position
De-Energized**

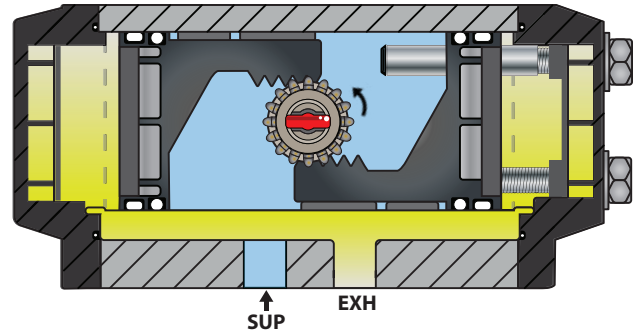

**(Fail CW Perpendicular)
Open Position
Energized**

Reverse Rotation

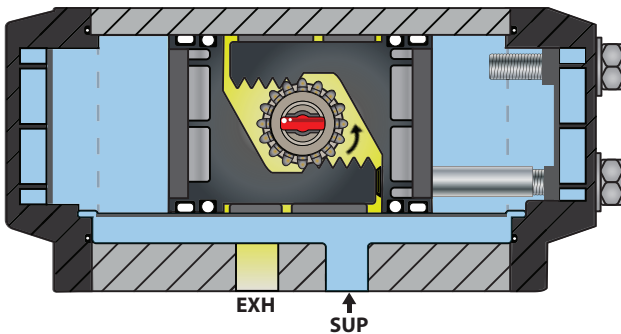

**(Fail CCW Parallel)
Open Position
De-Energized**

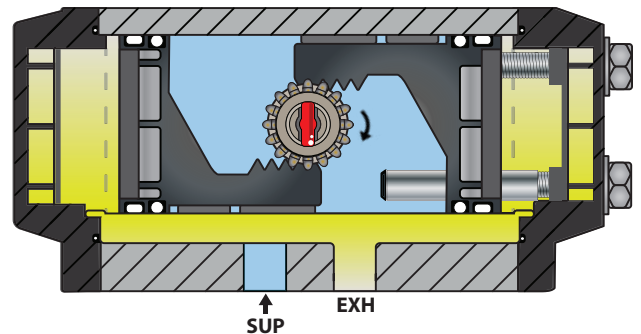

**(Fail CCW Parallel)
Closed Position
Energized**

NOTE

Fail positions only apply to spring return actuators or to double acting actuators using a left pilot solenoid valve

MT Series Technical Brochure

Max-Air Technology Inc. | Rotary Actuators & Valve Automation Solutions



maxairtech.com

Supply Air
Exhaust to Atmosphere

Standard Parallel

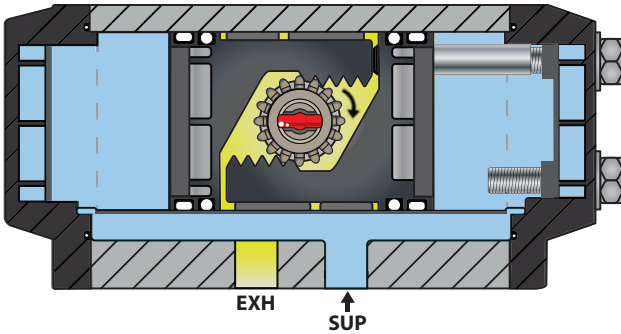

**(Fail CW Parallel)
Closed Position
De-Energized**

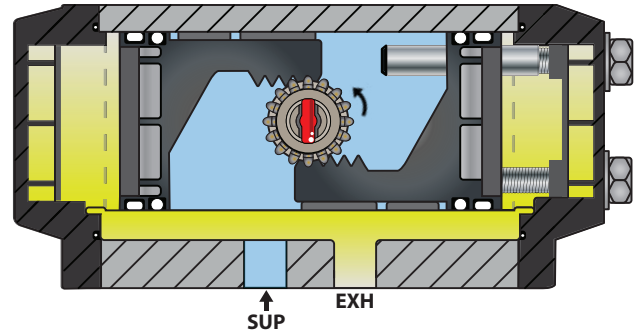

**(Fail CW Parallel)
Open Position
Energized**

Reverse Perpendicular

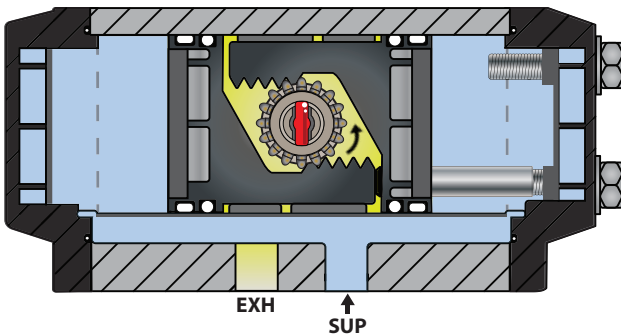

**(Fail CCW Perpendicular)
Open Position
De-Energized**

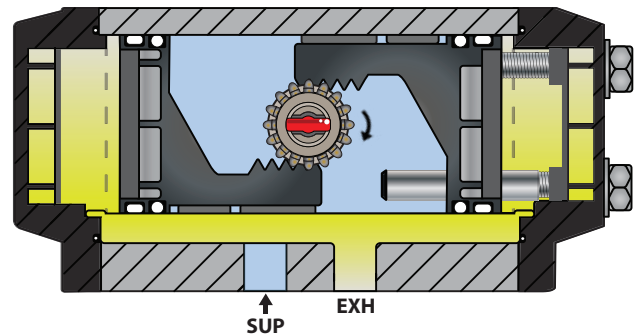

**(Fail CCW Perpendicular)
Closed Position
Energized**

Torque Data

Torques, Explanation of Sizing, Operation, & Spring Configuration

Double Acting: Torques, Sizing, & Configuration

Double Acting Torques

SIZE	40 psi	60 psi	80 psi	100 psi	120 psi
MT04	33	49	65	82	98
MT12	62	92	123	153	185
MT08	102	152	203	255	305
MT16	134	201	268	336	403
MT17	177	265	353	442	531
MT21	244	366	490	610	732
MT26	369	553	734	921	1106
MT31	490	736	979	1227	1472
MT36	786	1179	1568	1966	2359
MT41	984	1475	1961	2460	2952
MT46	1535	2303	3065	3838	4606
MT51	2277	3417	4542	5692	6833
MT56	2948	4422	5878	7370	8844
MT61	4818	7226	9604	12046	14451
MT66	5897	8845	11794	14742	17691
MT71	11545	17317	23088	28862	34634
MT76	15481	23220	30957	38695	46436

Explanation of Sizing

Rack & Pinion actuator produces a constant torque output (Fig A) that depends on the internal diameter and the air supply pressure: increasing one or both factors, torque increases.

Valve's operation torque is not constant but presents a trend different depending on valve's type.

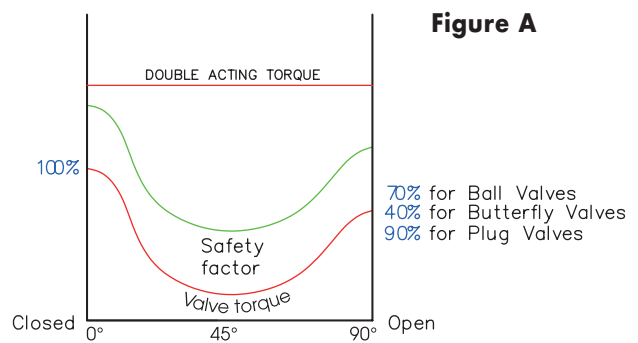

Prior to sizing it's necessary to obtain the following information and data:

- Type of valve and rated torque
- Air supply pressure

The sizing is as follows:

1. Define the maximum torque of the valve to automate, increasing to 5% ÷ 50% the rated torque of the valve (according to the type of valve working conditions).
2. Once the necessary torque value is set, with the torque chart, and, in relation to the corresponding air pressure, find the torque value exact or exceeding.
3. Once the torque value is set, the left column of the torque summary table will show the required

Illustration of Operation: Double Acting

Below show the operation of a Double Acting actuator when air is applied to either port.

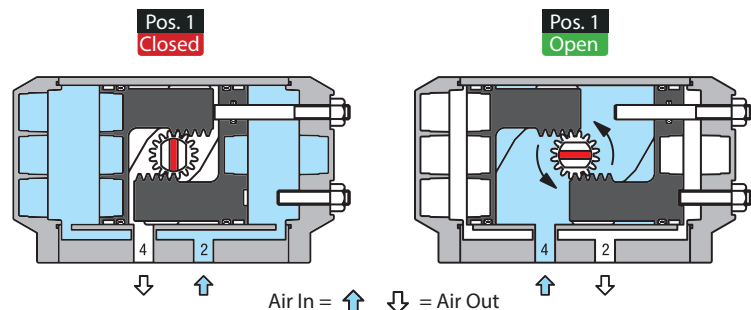



Spring Return: Torques, Sizing, & Configuration

Explanation of Sizing

The spring return actuator has a decreasing torque output throughout the stroke (Fig B). During the opening phase, the torque decreases, because the springs are compressed, and, working against the piston's stroke, absorb energy.

In the closing phase instead, the springs release this energy. So the torque is stated with 4 values:

- Opening Start/Pos. 2
- Opening End/Pos. 2
- Close Start/Pos. 1
- Close End/Pos. 1

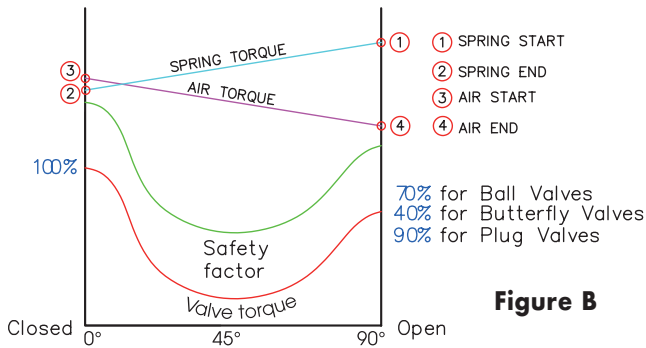
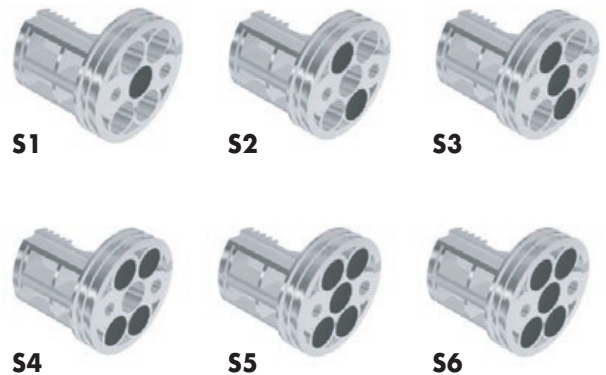

Figure B

To size and choose an actuator, proceed as follows:

1. To determine the needed torque, increase of 25% ÷ 50%, depending on the type of the valve and working conditions, the value of the rated valve torque.
2. Using the "Spring return 90°" table, locate the End/Pos. 1 column, with the torque value either exact or exceeding the needed torque.
3. According to the air pressure supply, locate the End/Pos. 2 column, with the torque value either exact or exceeding the needed torque.

Spring Assembly Right Position



Spring Assembly Left Position

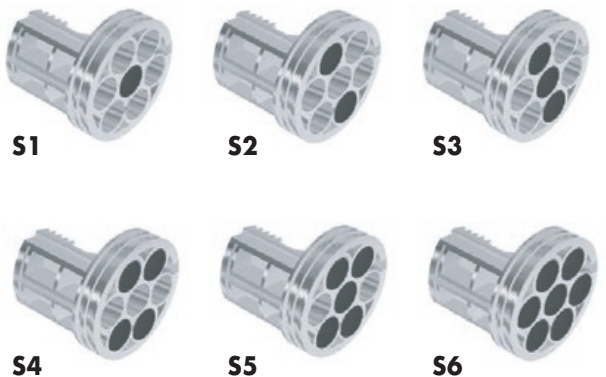
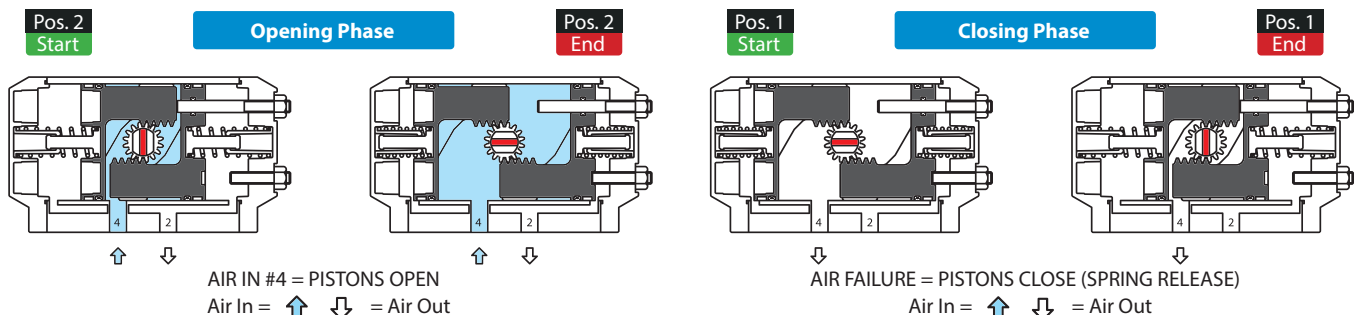

Illustration of Operation: Spring Return

Below show the operation of a Spring Return actuator when air is applied to either port.



Torques can be found on the following pages. →

Torque Data

Double Acting & Spring Return Torques for MT Series

Spring Return Torques

SIZE	SPRING CONFIG	# OF SPRINGS	SPRING TORQUES (IN-LBS)		40 psi		60 psi		80 psi		100 psi		120 psi	
			START	END	START	END	START	END	START	END	START	END	START	END
MT12	S1	2	33	22	40	29	70	60	100	90	131	121	163	152
	S2	4	65	44	--	--	48	27	78	57	109	88	141	119
	S3	6	99	66	--	--	--	--	56	24	87	55	118	86
MT08	S1	2	33	20	81	29	132	119	183	170	234	222	285	272
	S2	4	65	41	--	--	111	87	163	138	214	189	264	239
	S3	6	98	61	--	--	91	54	142	105	193	156	244	207
	S4	8	131	81	--	--	71	21	122	72	173	124	223	174
	S5	10	164	102	--	--	--	--	101	39	153	91	203	141
MT16	S2	4	74	53	81	60	148	127	213	194	283	261	350	328
	S3	6	112	81	54	23	121	90	188	157	255	224	322	291
	S4	8	150	107	--	--	94	52	161	119	229	186	296	253
	S5	10	187	134	--	--	68	15	135	82	202	149	269	216
	S7x5	12	224	160	--	--	--	--	108	45	175	112	243	179
MT17	S2	4	93	64	113	84	202	172	289	260	378	349	467	438
	S3	6	139	96	81	38	170	126	257	214	346	303	435	392
	S4	8	185	127	--	--	138	80	225	168	315	257	403	346
	S5	10	231	160	--	--	105	34	193	122	282	211	371	300
	S7x5	12	278	192	--	--	--	--	161	75	250	164	339	253
MT21	S2	4	122	92	152	122	274	244	398	368	518	488	640	610
	S3	6	184	138	106	60	228	182	352	306	472	426	594	548
	S4	8	245	184	--	--	182	121	306	245	426	365	548	487
	S5	10	306	230	--	--	136	60	260	184	380	304	502	426
	S7x5	12	368	276	--	--	--	--	214	122	334	242	456	364
MT26	S2	4	196	124	245	173	429	357	611	539	797	726	982	910
	S3	6	294	185	184	75	368	259	549	441	736	628	921	812
	S4	8	391	247	--	--	306	162	488	343	674	530	859	714
	S5	10	489	309	--	--	244	63	426	245	613	432	797	616
	S7x5	12	587	371	--	--	--	--	364	148	551	335	735	519
MT31	S2	4	250	187	303	240	549	485	793	729	1040	976	1285	1221
	S3	6	375	280	211	115	456	361	702	604	947	851	1192	1097
	S4	8	501	373	--	--	362	235	606	478	853	726	1098	971
	S5	10	626	466	--	--	269	110	513	354	760	601	1005	846
	S7x5	12	751	559	--	--	--	--	420	228	665	475	912	720
MT36	S2	4	412	306	480	374	873	767	1262	1156	1659	1554	2052	1947
	S3	6	617	460	326	169	719	562	1108	951	1505	1349	1898	1742
	S4	8	823	613	--	--	566	356	955	745	1352	1143	1745	1536
	S5	10	1028	766	--	--	413	151	801	539	1199	937	1592	1330
	S7x5	12	1235	920	--	--	--	--	647	333	1045	731	1438	1124
MT41	S2	4	504	371	613	479	1105	971	1591	1457	2089	1955	2581	2447
	S3	6	757	556	428	227	920	719	1406	1205	1904	1703	2396	2195
	S4	8	1010	741	--	--	735	466	1221	952	1719	1450	2211	1942

MT Series Technical Brochure

Max-Air Technology Inc. | Rotary Actuators & Valve Automation Solutions



maxairtech.com

Spring Return Torques Cont.

SIZE	SPRING CONFIG	# OF SPRINGS	SPRING TORQUES (IN-LBS)		40 psi		60 psi		80 psi		100 psi		120 psi	
			START	END	START	END	START	END	START	END	START	END	START	END
MT41 Cont.	S5	10	1262	927	--	--	549	213	1035	699	1533	1198	2025	1690
	S7x5	12	1514	1112	--	--	--	--	850	447	1348	946	1840	1438
MT46	S2	4	889	558	977	647	1744	1414	2506	2176	3280	2950	4047	3717
	S3	6	1333	838	697	202	1465	970	2226	1732	3000	2505	3768	3273
	S4	8	1777	1117	--	--	1186	526	1948	1287	2721	2061	3489	2829
	S5	10	2221	1397	--	--	906	81	1668	843	2442	1617	3209	2384
	S7x5	12	2666	1675	--	--	628	--	1389	399	2163	1172	2930	1940
MT51	S2	4	1148	831	1446	1129	2568	2245	3694	3370	4846	4523	6002	5685
	S3	6	1722	1247	1030	555	2144	1660	3269	2785	4422	3937	5586	5110
	S4	8	2297	1663	--	--	1720	1074	2845	2199	3998	3352	5170	4536
	S5	10	2870	2079	--	--	1296	489	2421	1614	3574	2766	4754	3962
	S7x5	12	3444	2494	--	--	--	--	1997	1028	3150	2180	4339	3388
MT56	S2	4	1486	1054	1894	1462	3368	2936	4824	4392	6316	5884	7790	7358
	S3	6	2228	1581	1366	719	2837	2193	4297	3650	5789	5142	7263	6616
	S4	8	2971	2109	--	--	2313	1451	3769	2907	5261	4399	6735	5873
	S5	10	3714	2636	--	--	1786	707	3243	2164	4735	3656	6209	5130
	S7x5	12	4457	3163	--	--	--	--	2715	1421	4207	2913	5681	4387
MT61	S2	4	2351	1757	3061	2467	5417	4806	7797	7185	10233	9622	12695	12101
	S3	6	2938	2196	2622	1880	4512	3595	6891	5975	9330	8413	12256	11513
	S4	8	4701	3513	1305	117	3607	2385	5987	4765	8425	7202	10938	9750
	S5	10	5876	4392	--	--	2703	1175	5082	3554	7520	5992	10059	8576
	S7x5	12	7051	5271	--	--	1955	175	4177	2343	6616	4782	9180	7401
MT66	S2	4	2806	2082	3815	3090	6764	6039	9712	8987	12665	11936	15609	14884
	S3	6	4210	3122	2775	1687	5723	4635	8671	7584	11620	10532	14568	13481
	S4	8	5613	4164	1733	284	4681	3233	7630	6181	10578	9129	13527	12078
	S5	10	7016	5205	--	--	3641	1829	6589	4777	9537	7726	12486	10674
	S7x5	12	8422	6245	--	--	2601	424	5549	3372	8498	6320	11446	9269
MT71	S2	4	4239	3062	8483	7306	14255	13078	20025	18848	25800	24623	31572	30395
	S3	6	6363	4593	6952	5182	12724	10954	18494	16724	24269	22499	30041	28271
	S4	8	8478	6124	5420	3066	11193	8839	16963	14609	22738	20383	28510	26155
	S5	10	10602	7664	3881	942	9653	6715	15423	12485	21198	18259	26970	24031
	S6	12	12726	9195	--	--	8122	4591	13892	10361	19667	16135	25439	21907
	S8	16	16965	12257	--	--	5060	352	10829	6121	16604	11896	22376	17668
MT76	S2	4	5682	3567	11914	9799	19654	17539	27390	25275	35128	33013	42870	40755
	S3	6	8284	5345	10136	7197	17875	14698	25611	22434	33349	30172	41091	38153
	S4	8	11363	7124	8357	4118	16096	11857	23833	19593	31570	27331	39312	35073
	S5	10	14195	8912	6569	1286	14308	9025	22045	16761	29783	24499	37524	32241
	S6	12	17036	10691	--	--	12529	6184	20266	13921	28004	21658	35746	29400
	S7	14	19877	12479	--	--	10742	3343	18478	11080	26216	18817	33958	26559
	S8	16	22718	14257	--	--	8963	502	16699	8239	24437	15977	32179	23718

MT04 Technical Data

Exploded View, Materials of Construction, & Dimensional Data

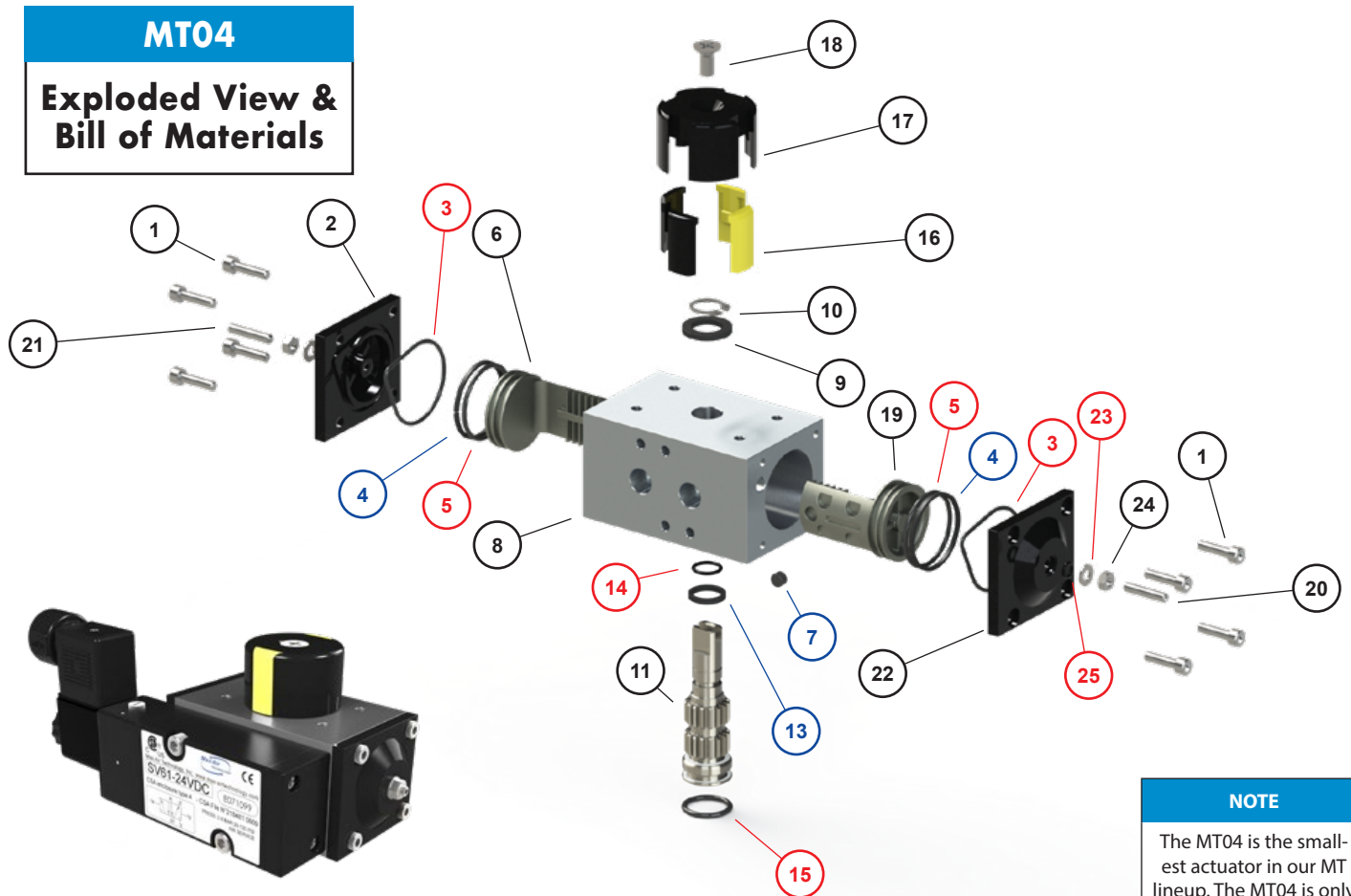

NOTE
The MT04 is the smallest actuator in our MT lineup. The MT04 is only available in double-acting configuration, and Standard Buna Seals.

IMPORTANT SPECIAL FEATURE!
The MAX-AIR MT04 is designed so that standard NAMUR mount solenoid valves can be connected horizontally. This is a MAX-AIR EXCLUSIVE feature.

Blue = Items sold in the skates and wear bearings repair kit
Red = Items sold in the o-ring repair kit

#	DESCRIPTION	MATERIALS
1	End Cap Bolts	AISI 304 Stainless Steel
2	Left End Cap	Die Cast Aluminum Epoxy Coated
6	Left Piston	Anodized Aluminum
8	Actuator Body	Extruded Aluminum (6063 or 6005)
9	Upper Pinion Washer	Technopolymer
10	Pinion Snap Ring	AISI 304 Stainless Steel
11	Pinion	Nickel Plated Carbon Steel
16	Indicator Inserts	Technopolymer
17	Indicator	Technopolymer
18	Indicator Screw	AISI 304 Stainless Steel
19	Right Piston	Anodized Aluminum
20	Travel Stop	AISI 304 Stainless Steel
21	Travel Stop	AISI 304 Stainless Steel
22	Right End Cap	Die Cast Aluminum Epoxy Coated
24	Travel Stop Nuts	AISI 304 Stainless Steel

#	DESCRIPTION	MATERIALS
4	Piston Wear Bearing	Technopolymer
7	Piston Skate	Technopolymer
13	Upper Pinion Bearing	Technopolymer

#	DESCRIPTION	MATERIALS
3	End Cap O-Ring	BUNA-N
5	Piston O-Ring	BUNA-N
14	Upper Pinion O-Ring	BUNA-N
15	Lower Pinion O-Ring	BUNA-N
23	Travel Stop Washers	AISI 304 Stainless Steel
25	Travel Stop O-Rings	BUNA-N

MT Series Technical Brochure

Max-Air Technology Inc. | Rotary Actuators & Valve Automation Solutions



maxairtech.com

MT04

*Only available in Double Acting configuration, and with Standard Buna-N Seals (-4°F to 176°F).

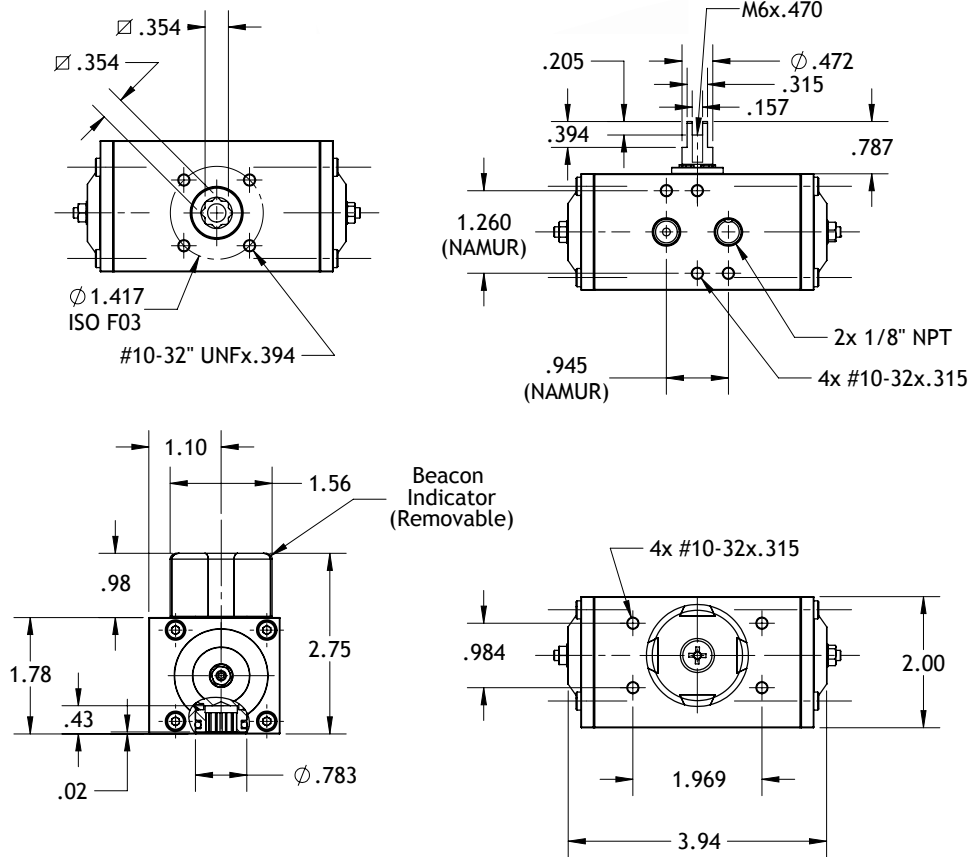

SERVICE	CODE	DESCRIPTION
Super Low Temperature	SLT	For super low temperatures down to -67°F, special super low temperature seals and lubricant must be used.
Severe Cold	LT	For temperatures below -4°F down to -49°F, special low temperature seals and lubricant must be used.
Standard*	STD	Actuators come standard with BUNA-N seals, which are good for normal temperature ranges of -4°F to 176°F.
Elevated Temperature	HT	For elevated temperatures up to 300°F, VITON® seals are available. Typical VITON® installations are good for 250°F continuous and 300°F cyclic.

MT12 Technical Data

Exploded View, Materials of Construction, & Dimensional Data

MT12 Exploded View & Bill of Materials

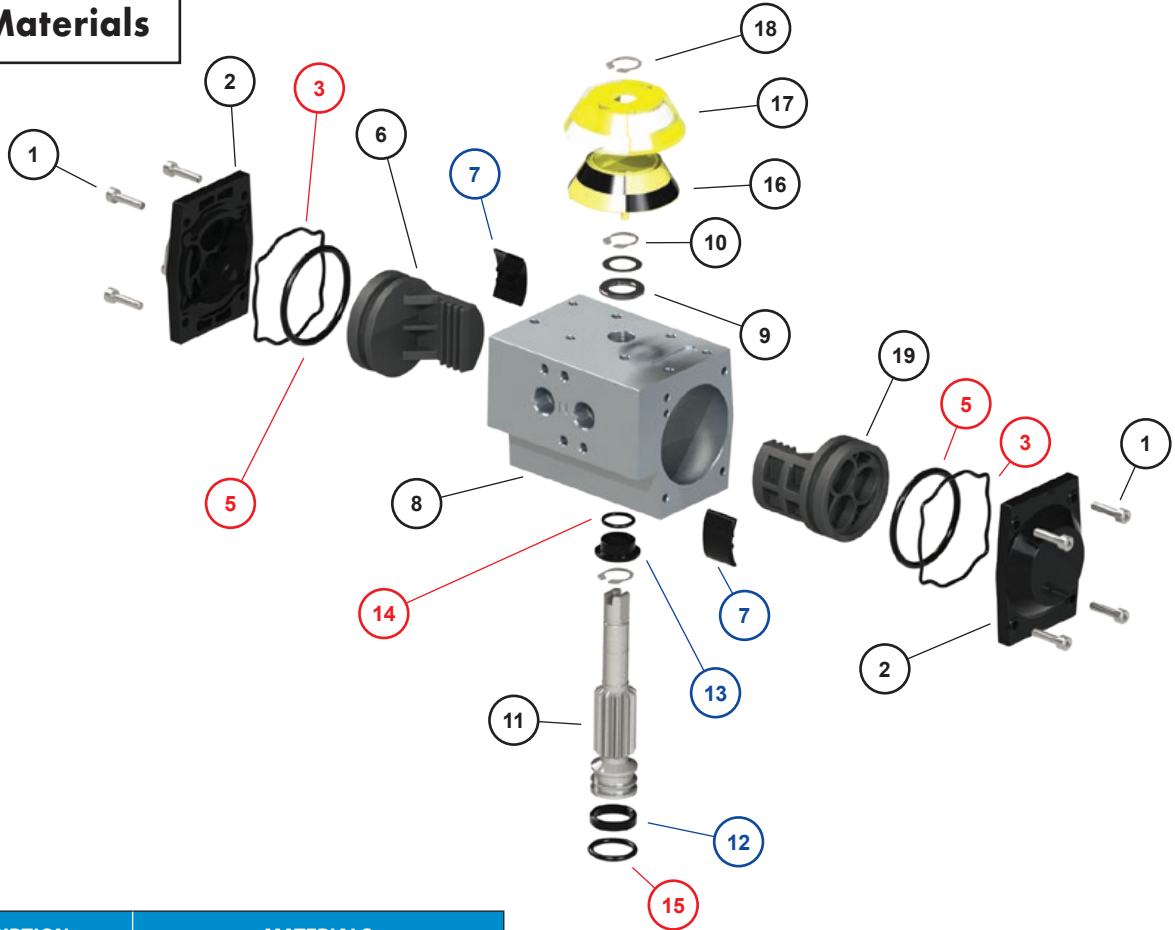

#	DESCRIPTION	MATERIALS
1	End Cap Bolts	AISI 304 Stainless Steel
2	Left End Cap	Die Cast Aluminum Epoxy Coated
6	Left Piston	Anodized Aluminum
8	Actuator Body	Extruded Aluminum (6063 or 6005)
9	Upper Pinion Washer	Technopolymer
10	Pinion Snap Ring	AISI 304 Stainless Steel
11	Pinion	Nickel Plated Carbon Steel
16	Open/Closed Indicator	Technopolymer
17	Indicator Window	Technopolymer
18	Indicator Snap Ring	AISI 304 Stainless Steel
19	Travel Stop Piston	Anodized Aluminum

SPECIAL NOTE

The second smallest actuator in our lineup, the MT12 actuator is designed without dual travel stop adjustments to save space, while at the same time offered in both DA (double-acting) and SR (spring-return) configurations. Available only in Standard Buna-N Seals (-4°F to 176°F).

Blue = Items sold in the skates and wear bearings repair kit
Red = Items sold in the o-ring repair kit

#	DESCRIPTION	MATERIALS
7	Piston Skate	Technopolymer
12	Lower Pinion Bearing	Technopolymer
13	Upper Pinion Bearing	Technopolymer

#	DESCRIPTION	MATERIALS
3	End Cap O-Ring	BUNA-N
5	Piston O-Ring	BUNA-N
14	Upper Pinion O-Ring	BUNA-N
15	Lower Pinion O-Ring	BUNA-N

MT Series Technical Brochure

Max-Air Technology Inc. | Rotary Actuators & Valve Automation Solutions



maxairtech.com

MT12

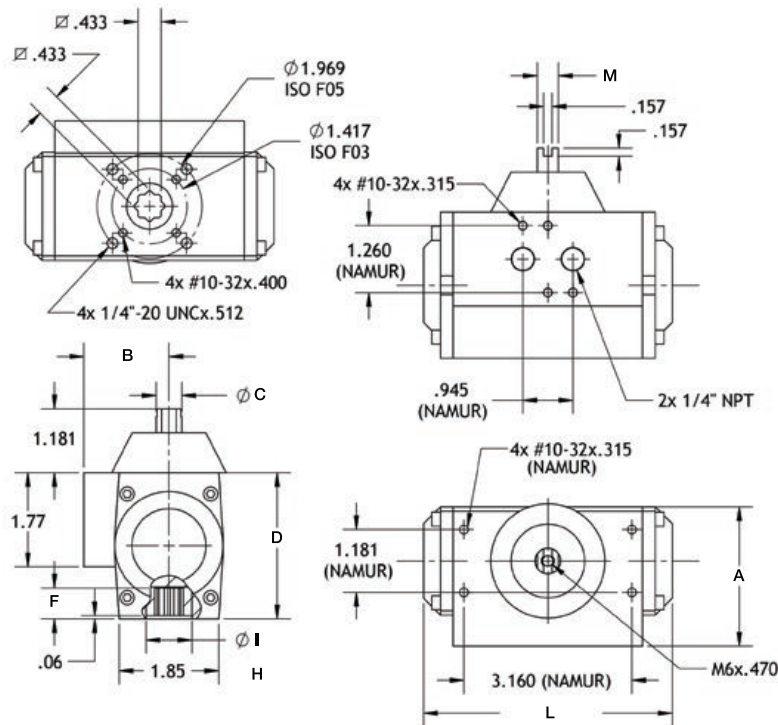

	A	B	ϕC	D	F	ϕI	L	M	F05	F03/F04	DSQ	ISO 5211
MT12	2.64	1.57	0.472	2.80	0.49	0.87	4.69	0.394	#10-32x.394	1/4"-20x.394	0.433	F03/F05
									#10-32x.394	—		F04

SERVICE	CODE	DESCRIPTION
Super Low Temperature	SLT	For super low temperatures down to -67°F, special super low temperature seals and lubricant must be used.
Severe Cold	LT	For temperatures below -4°F down to -49°F, special low temperature seals and lubricant must be used.
Standard*	STD	Actuators come standard with BUNA-N seals, which are good for normal temperature ranges of -4°F to 176°F.
Elevated Temperature	HT	For elevated temperatures up to 300°F, VITON® seals are available. Typical VITON® installations are good for 250°F continuous and 300°F cyclic.

*Only available with standard seals.

MT08 - MT66 Technical Data

Exploded View, Materials of Construction, & Dimensional Data

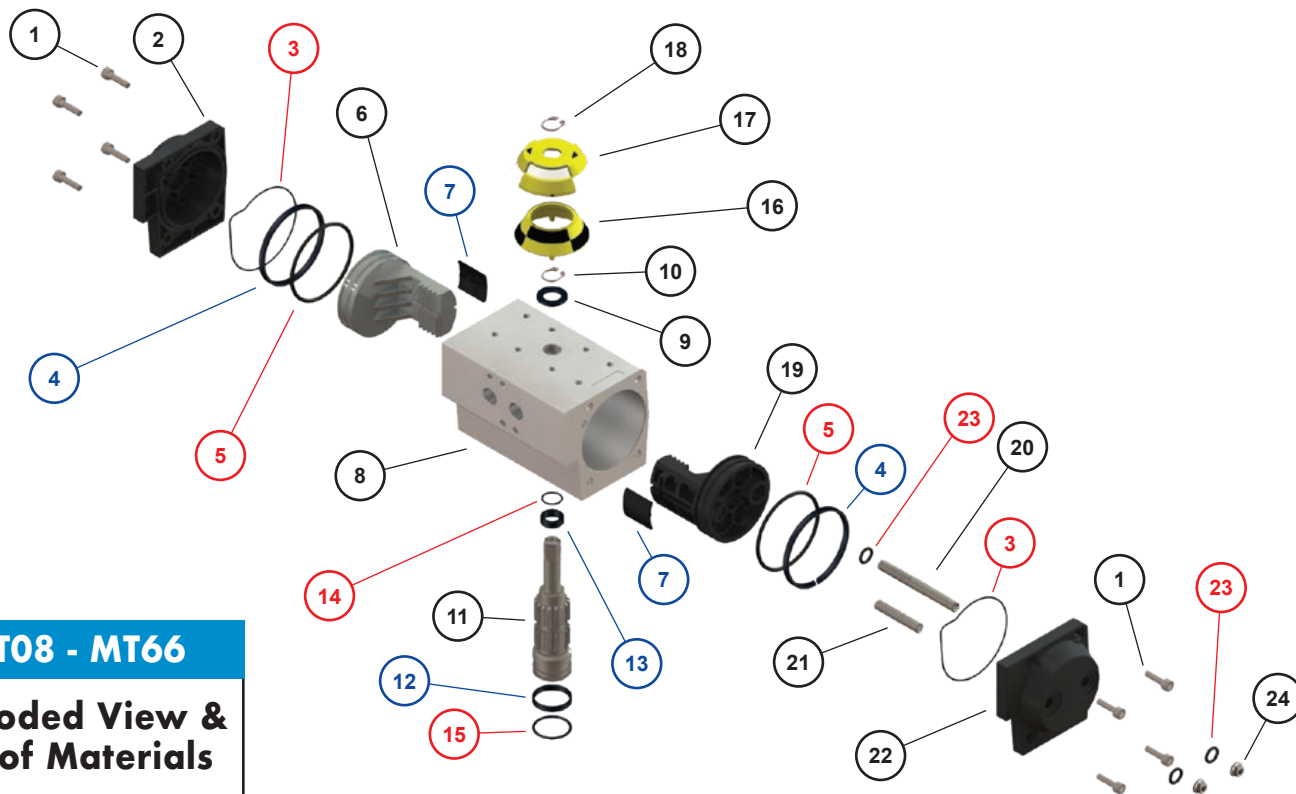

MT08 - MT66 Exploded View & Bill of Materials

#	DESCRIPTION	MATERIALS
1	End Cap Bolts	AISI 304 Stainless Steel
2	Left End Cap	Die Cast Aluminum Epoxy Coated
6	Left Piston	Anodized Aluminum
8	Actuator Body	Extruded Aluminum (6063 or 6005)
9	Upper Pinion Washer	Technopolymer
10	Pinion Snap Ring	AISI 304 Stainless Steel
11	Pinion	Nickel Plated Carbon Steel
16	Open/Closed Indicator	Technopolymer
17	Indicator Window	Technopolymer
18	Indicator Snap Ring	AISI 304 Stainless Steel
19	Travel Stop Piston	Anodized Aluminum
20	Closed Travel Stop	AISI 304 Stainless Steel
21	Open Travel Stop	AISI 304 Stainless Steel
22	Travel Stop End Cap	Die Cast Aluminum Epoxy Coated
24	Travel Stop Nuts	AISI 304 Stainless Steel

Blue = Items sold in the skates and wear bearings repair kit
Red = Items sold in the o-ring repair kit

#	DESCRIPTION	MATERIALS
4	Piston Wear Bearing	Technopolymer
7	Piston Skate	Technopolymer
12	Lower Pinion Bearing	Technopolymer
13	Upper Pinion Bearing	Technopolymer

#	DESCRIPTION	MATERIALS
3	End Cap O-Ring	BUNA-N
5	Piston O-Ring	BUNA-N
14	Upper Pinion O-Ring	BUNA-N
15	Lower Pinion O-Ring	BUNA-N
23	Travel Stop O-Rings	BUNA-N

SERVICE	CODE	DESCRIPTION
Super Low Temperature	SLT	For super low temperatures down to -67°F, special super low temperature seals and lubricant must be used.
Severe Cold	LT	For temperatures below -4°F down to -49°F, special low temperature seals and lubricant must be used.
Standard	STD	Actuators come standard with BUNA-N seals, which are good for normal temperature ranges of -4°F to 176°F.
Elevated Temperature	HT	For elevated temperatures up to 300°F, VITON® seals are available. Typical VITON® installations are good for 250°F continuous and 300°F cyclic.

MT Series Technical Brochure

Max-Air Technology Inc. | Rotary Actuators & Valve Automation Solutions



maxairtech.com

MT08 - MT66

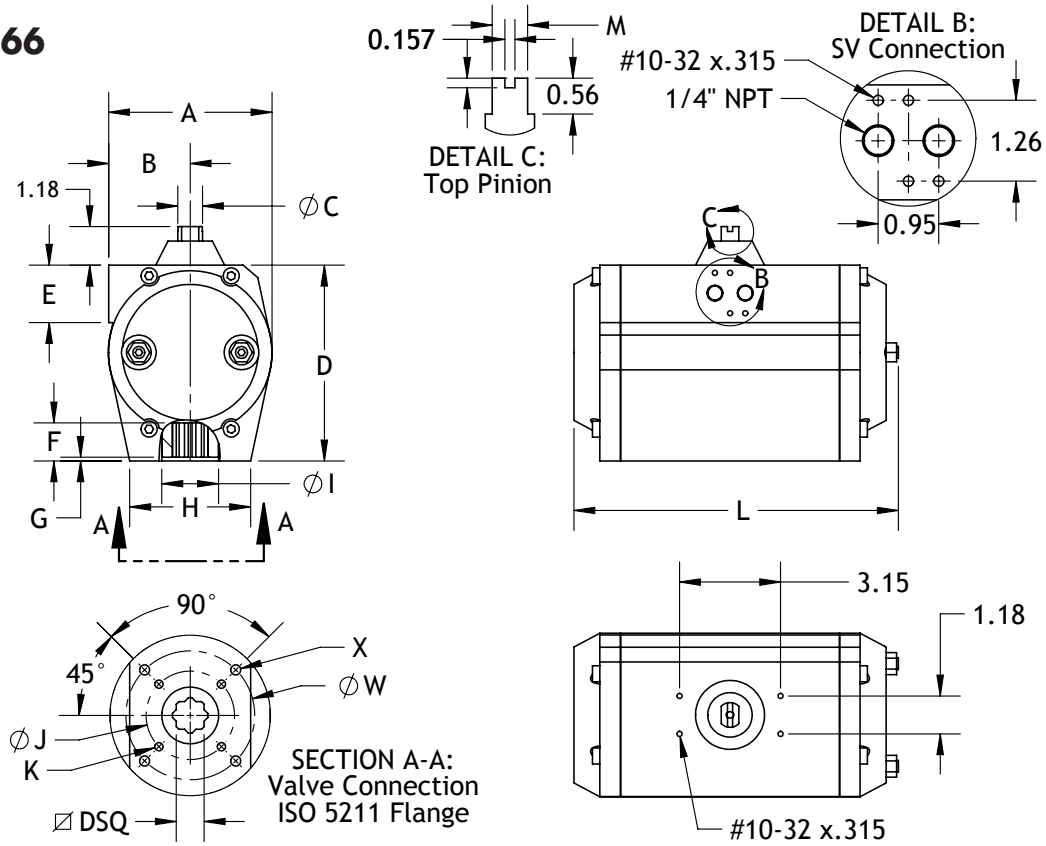

Note: Envelope dimensions shown, see individual cutsheets for dimensional details.

*Double-D and keyway drive options available. Contact Max-Air for details.

	A	B	ØC	D	E	F	G	H	ØI	L	M	ØJ	K	W	X	DSQ	ISO 5211
MT08	2.76	1.62	0.472	2.68	1.70	0.59	0.06	2.07	1.02	7.01	0.394	1.417	#10-32x.315	1.969	1/4"-20x.394	0.433	F03-F05
												1.654	#10-32x.315	-	-		F04
MT16	3.19	2.62	0.472	3.19	2.70	0.75	0.08	2.44	1.30	6.89	0.394	1.969	1/4"-20x.394	2.756	5/16"-18x.512	0.551	F05-F07
												1.654	#10-32x.394				-
MT17	3.19	1.85	0.472	3.19	1.75	0.75	0.08	2.44	1.30	8.15	0.394	1.969	1/4"-20x.394	2.756	5/16"-18x.512	0.551	F05-F07
MT21	3.78	2.13	0.551	3.86	2.75	0.75	0.08	3.01	1.38	7.32	0.394	1.969	1/4"-20x.512	2.756	5/16"-18x.512	0.669	F05-F07
MT26	3.78	2.13	0.768	3.86	3.75	0.91	0.08	3.01	1.59	9.76	0.551	1.969	1/4"-20x.512	2.756	5/16"-18x.512	0.669	F05-F07
MT31	4.49	2.44	0.768	4.61	4.75	0.91	0.08	3.56	1.59	9.49	0.551	1.969	1/4"-20x.512	2.756	5/16"-18x.512	0.669	F05-F07
MT36	5.16	2.60	0.768	6.06	5.75	1.18	0.12	3.76	1.59	10.28	0.551	2.756	5/16"-18x.512	4.016	3/8"-16x.709	0.866	F07-F10
MT41	5.16	2.60	0.768	6.06	6.75	1.18	0.12	3.76	1.77	12.01	0.551	2.756	5/16"-18x.512	4.016	3/8"-16x.709	0.866	F07-F10
MT46	5.71	2.87	1.102	6.63	7.75	1.18	0.12	3.88	2.22	14.45	0.787	2.756	5/16"-18x.512	4.016	3/8"-16x.709	0.866	F07-F10
MT51	7.13	3.58	1.102	7.95	8.75	1.22	0.12	4.33	2.15	14.98	0.787	4.016	3/8"-16x.709	4.921	1/2"-13x.787	1.063	F10-F12
MT56	7.13	3.58	1.102	7.95	9.75	1.46	0.12	4.90	2.62	16.85	0.787	4.016	3/8"-16x.709	4.921	1/2"-13x.787	1.063	F10-F12
														5.512	5/8"-11x.984		F10-F14
MT61	9.06	4.49	1.102	10.12	1.77	1.57	0.16	6.32	3.15	18.39	0.787	4.016	3/8"-16x.709	4.921	1/2"-13x.787	1.417	F10-F12
														5.512	5/8"-11x.984		F10-F14
MT66	9.06	4.49	1.102	10.12	1.77	1.57	0.16	6.32	3.15	20.67	0.787	4.016	3/8"-16x.709	4.921	1/2"-13x.787	1.417	F10-F12
														5.512	5/8"-11x.984		F10-F14

Note*: Dimensions subject to change without notice. Dimensions in inches unless otherwise noted.

MT71 - MT76 Technical Data

Exploded View, Materials of Construction, & Dimensional Data

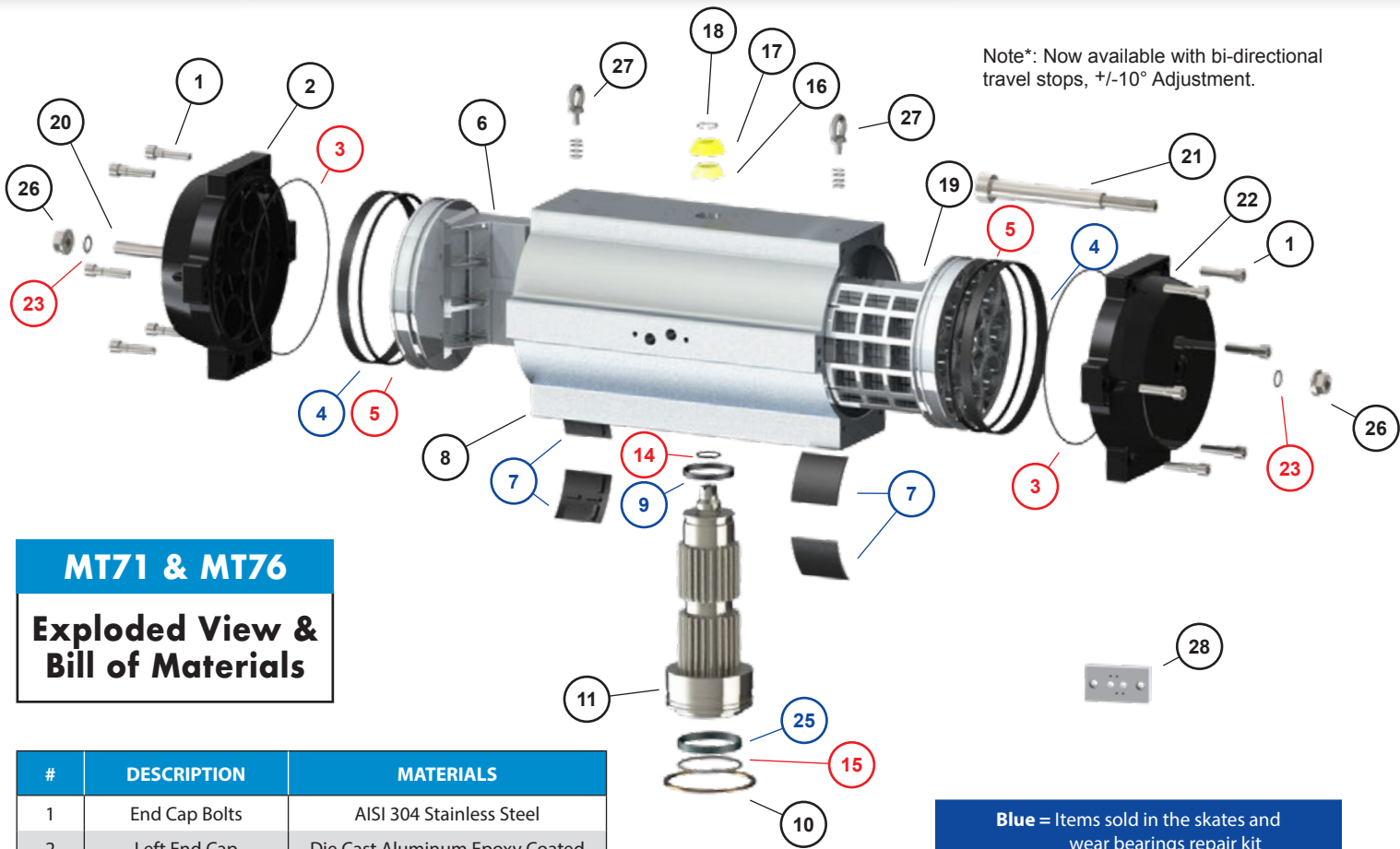

Note*: Now available with bi-directional travel stops, +/-10° Adjustment.

MT71 & MT76 Exploded View & Bill of Materials

#	DESCRIPTION	MATERIALS
1	End Cap Bolts	AISI 304 Stainless Steel
2	Left End Cap	Die Cast Aluminum Epoxy Coated
6	Left Piston	Anodized Aluminum
8	Actuator Body	Extruded Aluminum (6063 or 6005)
10	Pinion Snap Ring	AISI 304 Stainless Steel
11	Pinion	Nickel Plated Carbon Steel
16	Open/Closed Indicator	Technopolymer
17	Indicator Window	Technopolymer
18	Indicator Snap Ring	AISI 304 Stainless Steel
19	Right Piston	Anodized Aluminum
20	Travel Stop, Open	AISI 304 Stainless Steel
21	Travel Stop, Closed	AISI 304 Stainless Steel
22	Right End Cap	Die Cast Aluminum Epoxy Coated
26	Travel Stop Nut	AISI 304 Stainless Steel
27	Lifting Eyelets	Forged Stainless Steel
28	Adapter Plate	Aluminum

Blue = Items sold in the skates and wear bearings repair kit
Red = Items sold in the o-ring repair kit

#	DESCRIPTION	MATERIALS
4	Piston Wear Bearing	Technopolymer
7	Piston Skates	Technopolymer
9	Upper Pinion Bearing	Technopolymer
25	Lower Pinion Bearing	Technopolymer

#	DESCRIPTION	MATERIALS
3	End Cap O-Ring	BUNA-N
5	Piston O-Ring	BUNA-N
14	Upper Pinion O-Ring	BUNA-N
15	Lower Pinion O-Ring	BUNA-N
23	Travel Stop O-Rings	BUNA-N

SERVICE	CODE	DESCRIPTION
Super Low Temperature	SLT	For super low temperatures down to -67°F (-55°C), special super low temperature seals and lubricant must be used.
Severe Cold	LT	For temperatures below -4°F (-20°C) down to -49°F (-45°C), special low temperature seals and lubricant must be used.
Standard	STD	Actuators come standard with BUNA-N seals, which are good for normal temperature ranges of -4°F (-20°C) to 176°F (80°C).
Elevated Temperature	HT	For elevated temperatures up to 300°F, VITON® seals are available. Typical VITON® installations are good for 250°F continuous and 300°F cyclic.

MT Series Technical Brochure

Max-Air Technology Inc. | Rotary Actuators & Valve Automation Solutions



maxairtech.com

MT71

Adapter Plate Required
for NAMUR Accessories

See next page for details.

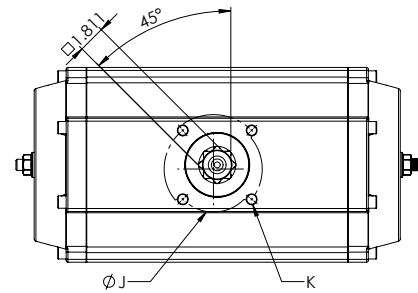
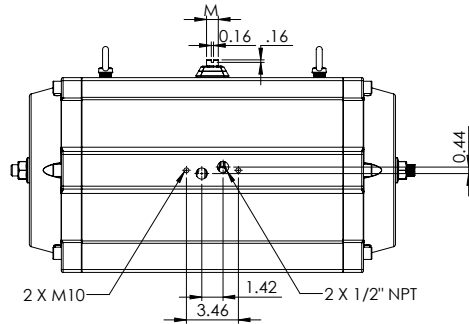
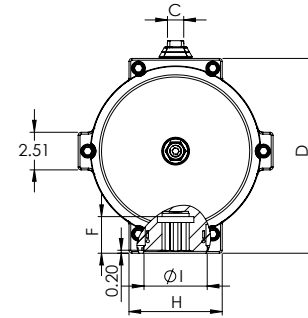
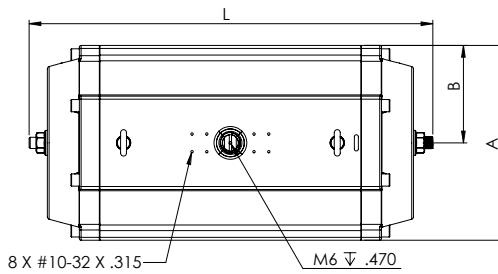
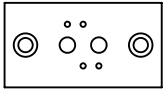

*Double-D and keyway drive options available. Contact Max-Air for details.

	A	B	ØC	D	F	H	ØI	L	M	ØJ	K	DSQ	ISO 5211
MT71	12.99	6.50	1.102	4.33	2.44	6.22	3.82	24.41	0.79	6.496	3/4"-10x1.260	1.811	F16
MT76	12.99	6.50	1.102	4.33	2.44	6.22	5.51	27.95	0.79	6.496	3/4"-10x1.260	1.811	F16

MT76

Adapter Plate Required
for NAMUR Accessories

See next page for details.

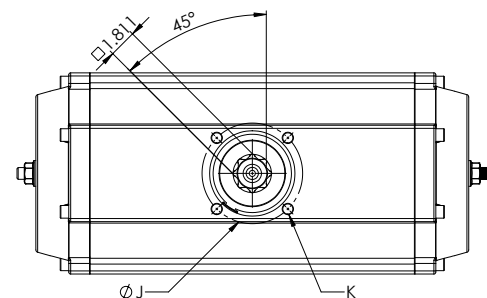
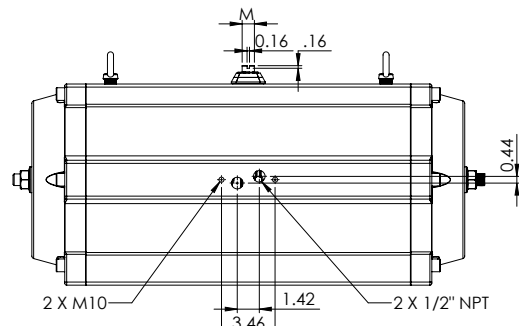
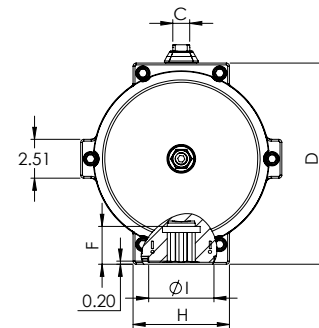
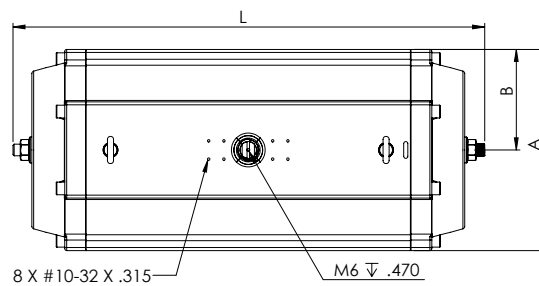
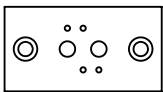

*Double-D and keyway drive options available. Contact Max-Air for details.

MT71 - MT76 Technical Data Cont.

Exploded View, Materials of Construction, & Dimensional Data

MT71 & MT76 NAMUR Mounting Plate

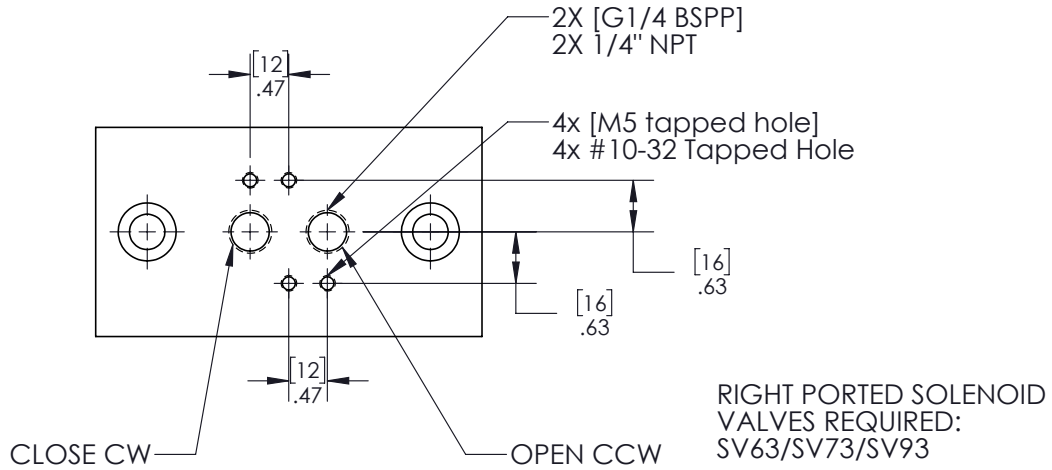

MT71 Dimensions w/ Plate

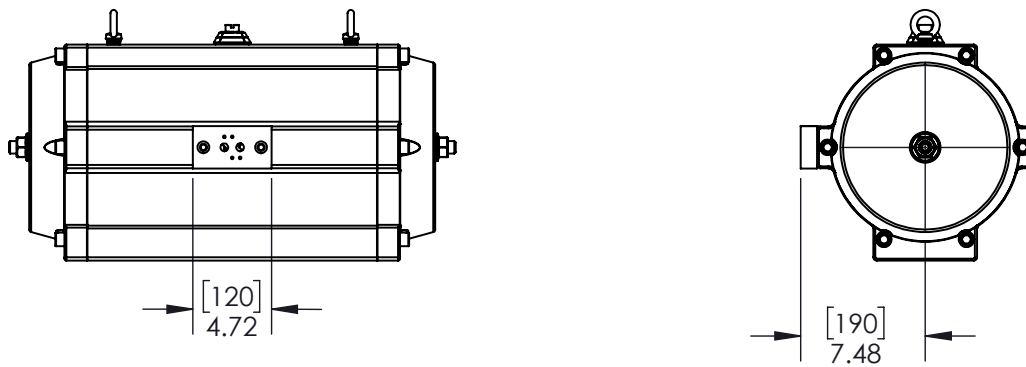

MT76 Dimensions w/ Plate

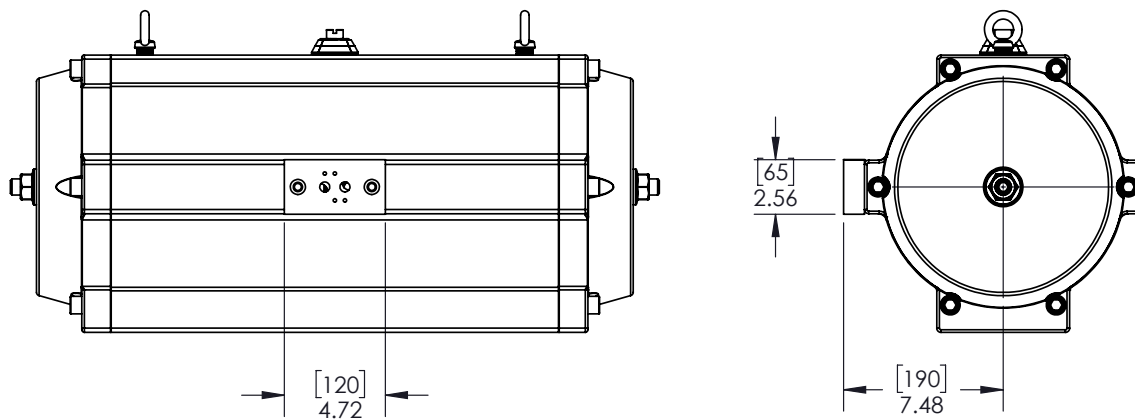

MT Series Technical Brochure

Max-Air Technology Inc. | Rotary Actuators & Valve Automation Solutions



maxairtech.com

This section left intentionally blank.

Standards, Certifications & Approvals

ISO 5211, CE, NAMUR, Atex, SIL3, DNV



ISO 5211 Mounting

This standard defines a standardized interface system between industrial valves and the part turn actuators used operate them. It details the dimensional requirements for both the mounting flanges on both devices as well as the driving and driven components. This standardization simplifies the design of or eliminates the need for interface components between part turn valves and actuators.



Atex Global Approval:

In addition to being designed and produced according to sound engineering practice, the MT series actuators have also been certified to the relevant Atex standards for safety (Machinery Directive, annex VIII B). Additionally it carries a CE mark and is in compliance with Annex VIII B of the Machinery Directive and regulation 80079-36.



CE Marking

This is a mandatory conformity marking for certain products sold within the European Economic Area (EEA) since 1985. The CE marking is also found on products sold outside the EEA that are manufactured in, or designed to be sold in, the EEA. This makes the CE marking recognizable worldwide even to people who are not familiar with the European Economic Area. It is in that sense similar to the FCC Declaration of Conformity used on certain electronic devices sold in the United States. The CE marking is the manufacturer's declaration that the product meets the requirements of the applicable EC directives.



SIL3 Approval

The MT series actuators have been independently evaluated by approval authorities which have confirmed that our actuators are SIL 3 capable in accordance with the requirements of IEC 61508 provided that they are installed in accordance with the relevant Safety Manual.



DNV Approval

DNV-GL Italy/Malta understood an evaluation of the Max-Air MT series actuators and found them in compliance with:

- DNV GL rules for classification – Ships Pt.4 Ch.6 Piping systems Offshore
- Standard DNV-OS-D101, Marine and Machinery Systems and Equipment



NAMUR

All MT series actuators (with the exception of the MT04 size) come with NAMUR accessory interfaces according to VDI/VDE 3845. The air interface is in the 1/4" size.

MT Series Technical Brochure

Max-Air Technology Inc. | Rotary Actuators & Valve Automation Solutions



maxairtech.com

This section left intentionally blank.

MAX-AIR TECHNOLOGY

The Best Way To Automate Your Process



Your nearest Max-Air dealer can be found at:



maxairtech.com

Max-Air Technology, Inc. • 114 Resource Drive • Wentzville, MO 63385 • United States of America
Tel +1.636.272.4934 • Toll Free 888.842.9998 • Fax 636.272.4937 • www.maxairtech.com • info@maxairtech.com

© Max-Air Technology, Inc. 2020



R: 07/7/25